

# Pyramid Series Proximity™ Readers

The Pyramid Series Proximity line of OEM Proximity Readers can be used with virtually any manufacturer's access panel because the readers produce industry standard pass-through Wiegand (26-bit or custom formats) or magnetic stripe output. Readers can be configured to work with access panels using either single or dual LED control lines.

Optionally, Pyramid Series readers can be configured in the factory to read standard formatted HID credentials<sup>1</sup>. Pyramid Series readers are able to read the following Pyramid Series credentials.

- PSC-1 Standard Light Proximity Cards
- PSM-2 Multi Technology Cards
- PSK-3 Proximity Key Tags

When a card or tag is read, a Pyramid Series reader immediately responds with a beep and an LED flash<sup>2</sup>. The access panel then handles subsequent LED and beeper responses. Both the beep and the flash in this "Beep-n-Flash" feature can be disabled. Pyramid Series readers also feature built-in diagnostics: a start-up self test to ensure reader functionality and a data line test to ensure reader/access panel communication.

The Pyramid Series features five readers, each with its own unique characteristics, to meet virtually any requirements an end-user may have.

- The **P-300 Cascade Proximity Reader** is intended for installation on a window mullion or a door frame, in proximity applications where an unobtrusive reader is required. It can be mounted on metal or non-metal surfaces without loss of read range.
- The **P-400 Gibraltar Proximity Reader** is intended for mounting on a flat surface or a solid metal surface, in proximity applications where a vandal-resistant reader is required.
- The **P-500 Alps Proximity Reader** is intended for mounting on a flat non-metal surface or on a standard U.S. single-gang electrical box (if the electrical box is metal, the provided standoff must be used).
- The **P-600 Rocky Proximity Reader and Keypad** combines a Pyramid Series reader and a stainless steel Essex Keypad™ into one attractive package. The P-600 reader can be used in applications requiring single verification, either via proximity access or PIN, but it is typically used in applications requiring dual verification - an individual requesting access to a secure area must have both a valid proximity access credential and a valid Personal Identification Number (PIN). To use the P-600 reader for dual verification the access panel must be capable of handling the Wiegand format for the proximity section and either the 8-bit burst or 26-bit Wiegand format for the keypad section. The P-600 is designed for mounting on a flat, non-metal surface or on a standard U.S. single-gang electrical box.
- The **P-700 Yukon Reader** is intended for mounting where a longer read range contributes to the convenience of the access system; such as parking lots, employee entrances, and physically challenged (ADA requirement) access applications. Due to the reader's longer read range, care must be taken in mounting the reader in environments where metal and sources of electromagnetic or radio frequency interference is present.

---

1. See Section 1.0 [HID Compatibility](#) for more information.



2. The P-400 Gibraltar Proximity Reader does not have an LED to maximize its vandal resistance.



# Pyramid Series Proximity™ Readers

The electronics for the P-300, P-500, P-600, and P-700 readers is housed in a weatherproof, shock resistant package. This package is mounted to the installation surface. An attractive, snap-on, scratch-resistant, black or off-white front cover hides the electronics package and installation mounting hardware providing an extra level of security.

The electronics for the P-400 reader is housed in a stainless steel package, designed to be weather, vandal, and bullet resistant.

All Pyramid Series readers are compliant with the following organizations: FCC, , and .

## 1.0 HID Compatibility

Pyramid Series readers can be configured in the factory to read HID's standard proximity access control cards, including the ProxCard II, ISOProx II, and ProxKey II in 26-bit and other Wiegand formats, as well as all Pyramid Series credentials. Readers configured to be HID compatible, an optional feature, will have the following sticker on the back side of the reader. When ordering readers that are HID compatible, the letter "H" will be added to the reader name identifying it as HID compatible. For example, the P-300 reader that is HID compatible will be called P-300H.



HID compatible Pyramid Series Readers do not require any special wiring connections. There might be read range differences between HID cards and Pyramid Series credentials. The reader will beep and flash twice to indicate it has read a non standard HID card.

*NOTE: If you are enrolling cards for a "hybrid" site (one using both Pyramid series and HID credentials), it is possible to have duplicate card coding (i.e. identical format, facility code, and ID number).*

# Pyramid Series Proximity™ Readers

## 2.0 Reader Specifications

**Table 1: Reader Specifications**

	<b>P-300</b>	<b>P-400</b>	<b>P-500</b>	<b>P-600</b>	<b>P-700</b>
<b>Dimensions</b>	3.0" H x 1.5" W x 0.5" D	5.25" H x 2" W x 0.75" D	4.5" H x 3" W x 0.4" D	4.4" H x 3.9" W x 0.95" D	8.5" H x 6.0" W x 1.0" D
	76 mm H x 38 mm W x 12 mm D	133.5 mm H x 51 mm W x 19 mm D	114 mm H x 76 mm W x 10 mm D	112 mm H x 99 mm W x 24 mm D	216 mm H x 152 mm W x 25.5 mm D
<b>Operating Voltage<sup>a</sup></b>	5 to 14 VDC @	5 to 14 VDC @	5 to 14 VDC @	5 to 14 VDC @	5 to 14 VDC @
<b>Current Draw</b>	80 mA nominal	90 mA nominal	80 mA nominal	100 mA nominal	285 mA nominal
<b>Operating Temperature</b>	- 40°C to +65°C (- 40°F to +150°F)	- 40°C to +65°C (- 40°F to +150°F)	- 40°C to +65°C (- 40°F to +150°F)	- 40°C to +65°C (- 40°F to +150°F)	- 40°C to +65°C (- 40°F to +150°F)
<b>Frequency</b>	125 KHz excitation	125 KHz excitation	125 KHz excitation	125 KHz excitation	125 KHz excitation
<b>Audio Tone</b>	standard	standard	standard	standard	standard
<b>LED Indicator</b>	4-state: Red, Green, Amber, Off	not applicable	4-state: Red, Green, Amber, Off	4-state: Red, Green, Amber, Off	4-state: Red, Green, Amber, Off
<b>Front Cover Colors<sup>b</sup></b>	Black or Off-White	Stainless Steel & Fiber-Tex®	Black or Off-White	Black or Off-White	Black or Off-White

a. A supply voltage of 12 VDC at the reader is recommended for best operation.

b. Except for the P-400 reader, all readers ship with both black and off-white front covers.



# Pyramid Series Proximity™ Readers

## 2.1 Read Range

Read range is measured in a clean RF and electrical environment using a Pyramid Series Standard Light Proximity Card (PSC-1) presented parallel to the reader surface with the reader operating at 12 VDC. Like all manufacturers of Proximity Readers, Keri recommends a good quality, regulated, linear power supply (such as Keri Systems' KPS-5) be used with all proximity readers.

**Table 2: Read Range**

Reader	Standard Light Proximity Card	Multi Technology Card	Proximity Key Ring Tag
P-300	up to 4 inches (102 mm)	up to 3 inches (76 mm)	up to 2 inches (51 mm)
P-400	up to 1 inch (25 mm)	up to 1 inch (25 mm)	up to 1 inch (25 mm)
P-500 <sup>a</sup>	up to 5 inches (127 mm) using a spacer	up to 4 inches (102 mm)	up to 3 inches (76 mm)
P-600	up to 4 inches (102 mm)	up to 3 inches (76 mm)	up to 2 inches (51 mm)
P-700 <sup>b</sup>	up to 14 inches (356 mm)	up to 10 inches (254 mm)	up to 6 inches (152 mm)

- When using the provided spacer to separate the reader from a metal electrical box.
- When spacing the reader at least 5 inches (127 mm) from any metal surface.

Due to the physical size difference between the coils of various credentials, Multi Technology Proximity Cards (PSM-2) and Proximity Key Ring Tags (PSK-3) provide less read range than Standard Light Proximity cards (approximately 75% less and 50% less respectively). Read range will be reduced if a reader is located in electrical or RF noisy environments such as mounted near a computer monitor, powered by a switching power supply, or a lack of a good earth ground. Operation at 5 VDC also might reduce read range.

## 2.2 Cable Requirements

All readers operate with up to 500 feet (152 m) of cable, using seven-conductor<sup>1</sup>, shielded, stranded cable. Per Wiegand specification, AWG 24 (such as Belden 9537) is the minimum gauge required for data transfer in a 500-foot run length. However, the proper wire gauge to use must be determined by the current draw requirements of the reader, the length of the cable run, and the voltage being applied to the reader.

If the reader is to be operated at 5 VDC, 5 VDC must be available at the reader (long cable runs have a voltage drop due to the resistance in the cable). A larger gauge of wire (having less resistance) or a separate power supply near the reader may be required to ensure 5 VDC is available at the reader.

- Seven-conductor cable is necessary for dual LED, however less may be used with single LED. The P-400 only requires five-conductor cabling (such as Belden 9535).



# Pyramid Series Proximity™ Readers

## 3.0 Reader Configuration

There are no switches or jumpers to set. All Pyramid Series readers are compatible with and can be connected to virtually any access panel that meets Wiegand or magnetic stripe interface standards. All connections needed to support the reader are made through the reader's cable. Please consult the [Wiring Connections](#) section on page 10 for wiring instructions.

### 3.1 P-300 Cascade Reader Mounting Instructions

Three holes need to be drilled to mount the P-300 Reader's electronics package (refer to the Figure below). One large hole (7/8 inch - 22 mm) accommodates the beeper and the reader cable. Two small pilot holes for a #6 screw (1/8 inch - 3 mm) are for mounting the electronics package on the mullion or door frame.

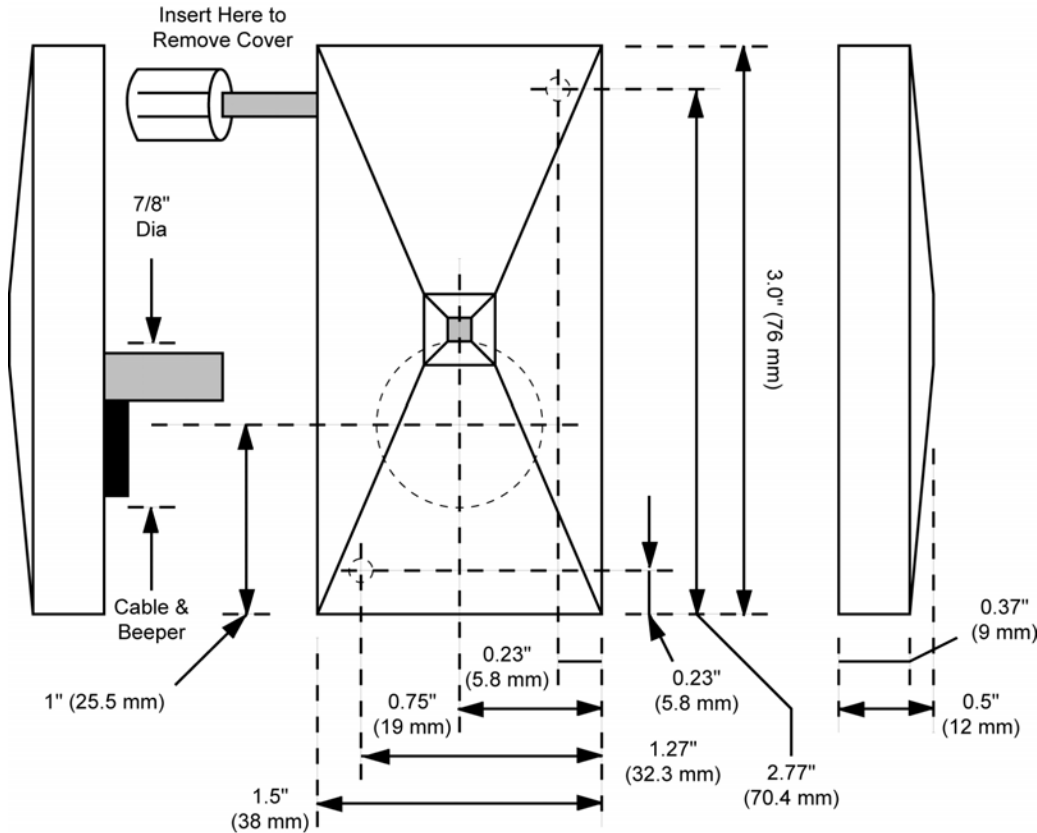

Figure 1: P-300 Mounting Diagram

# Pyramid Series Proximity™ Readers

## 3.2 P-400 Gibraltar Reader Mounting Instructions

There are two methods for mounting the Gibraltar Reader on a solid metal surface (see Figure 2).

1. To mount the reader from the outside, three holes need to be drilled. One through-hole (3/4" - 19 mm) accommodates the reader cable. Two holes correspond with two 1/4", countersunk through-holes in the face of the reader (hole size is dependent upon the size of the mounting screw).
2. To mount the reader from the inside, five holes need to be drilled. One through hole (3/4" - 19 mm) accommodates the reader cable. Four 1/4" through holes correspond with four 1/4" x 20 tapped holes in the back of the reader. Drill these holes to accommodate 4 - 1/4" x 20 bolts.

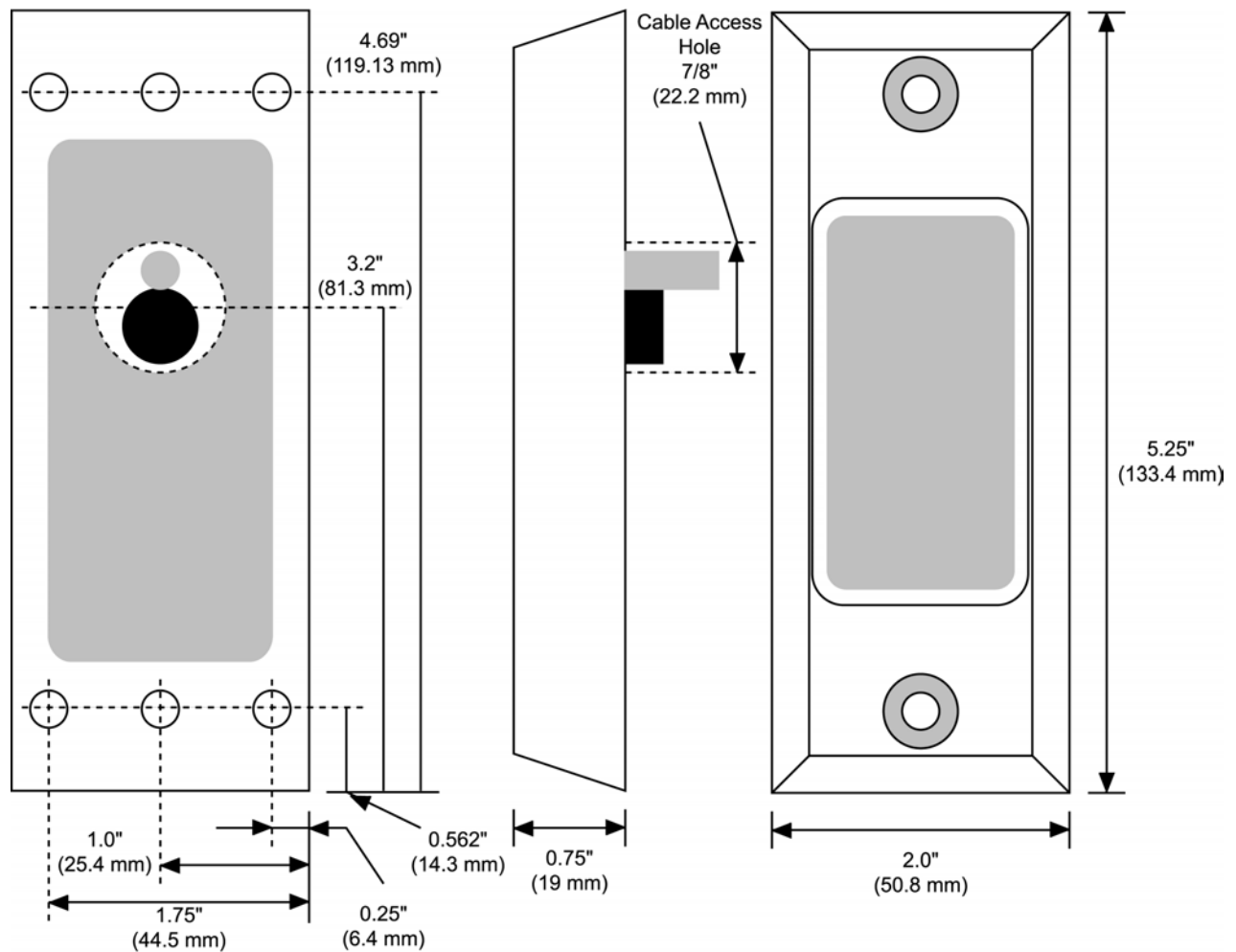

Figure 2: P-400 Mounting Diagram

# Pyramid Series Proximity™ Readers

## 3.3 P-500 Alps Reader Mounting Instructions

Three holes need to be drilled to mount the P-500 Reader's electronics package (see Figure 3). One large hole (7/8 inch - 22 mm) accommodates the beeper and the reader cable. Two small pilot holes for a #6 screw (1/8 inch - 3 mm) are for mounting the electronics package on a wall surface. Drilling is not required if the reader is to be mounted to a standard U.S. single gang electrical box - the electronics package is mounted directly to the box.

When mounting to a single gang electrical box, if the box is made of plastic, the electronics package can be mounted directly to the box. If the box is made of metal, a 1/2 inch thick, plastic spacer is necessary to prevent the metal of the box from interfering with the reader's read range.

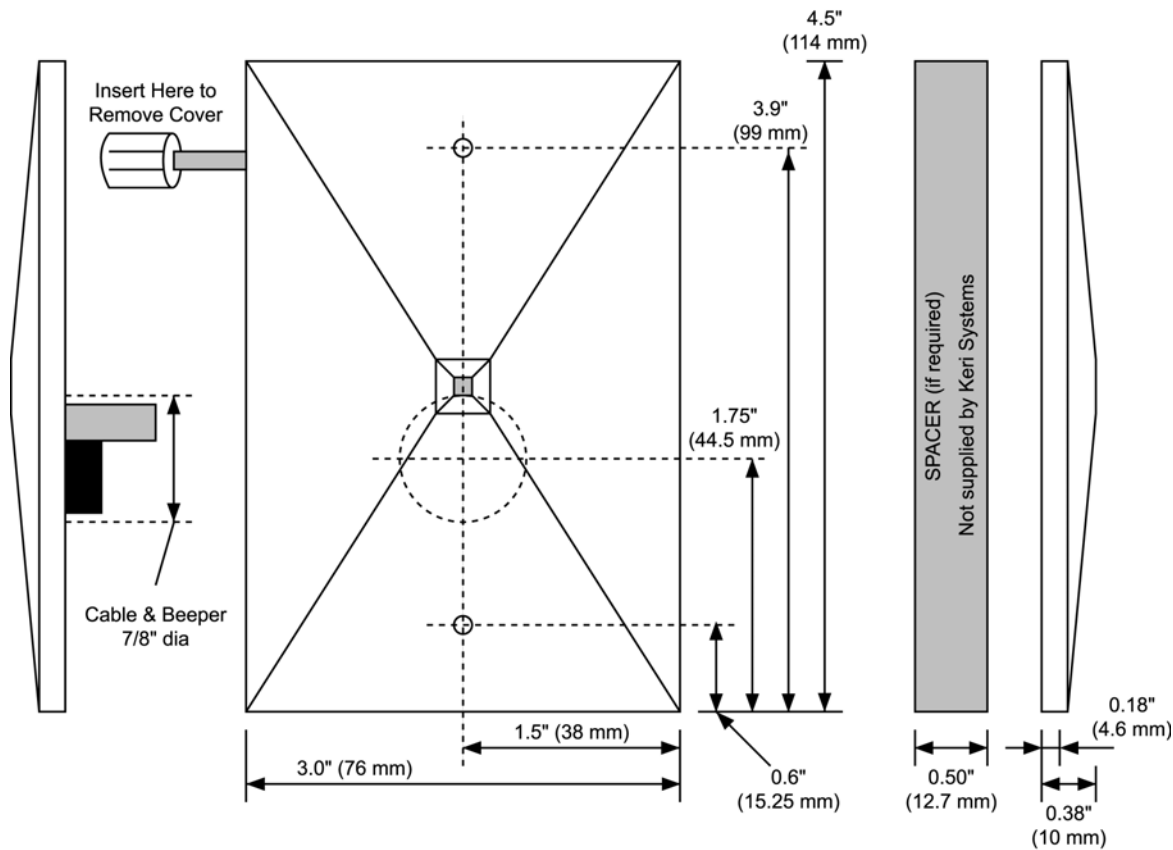

Figure 3: P-500 Mounting Diagram

# Pyramid Series Proximity™ Readers

## 3.4 P-600 Rocky Reader and Keypad Mounting Instructions

When mounting to a flat surface, three holes need to be drilled to mount the P-600's electronics package (refer to Figure 4). One large hole (1 inch - 25.5 mm) accommodates the beeper and the reader cable (please note that the beeper and reader cable hole is not located on the reader's center line). Two small pilot holes for a #6 screw (1/8 inch - 3 mm) are for mounting the electronics package on a wall surface.

Drilling is not required if the reader is to be mounted to a standard U.S. single gang electrical box - the electronics package is mounted directly to the electrical box.

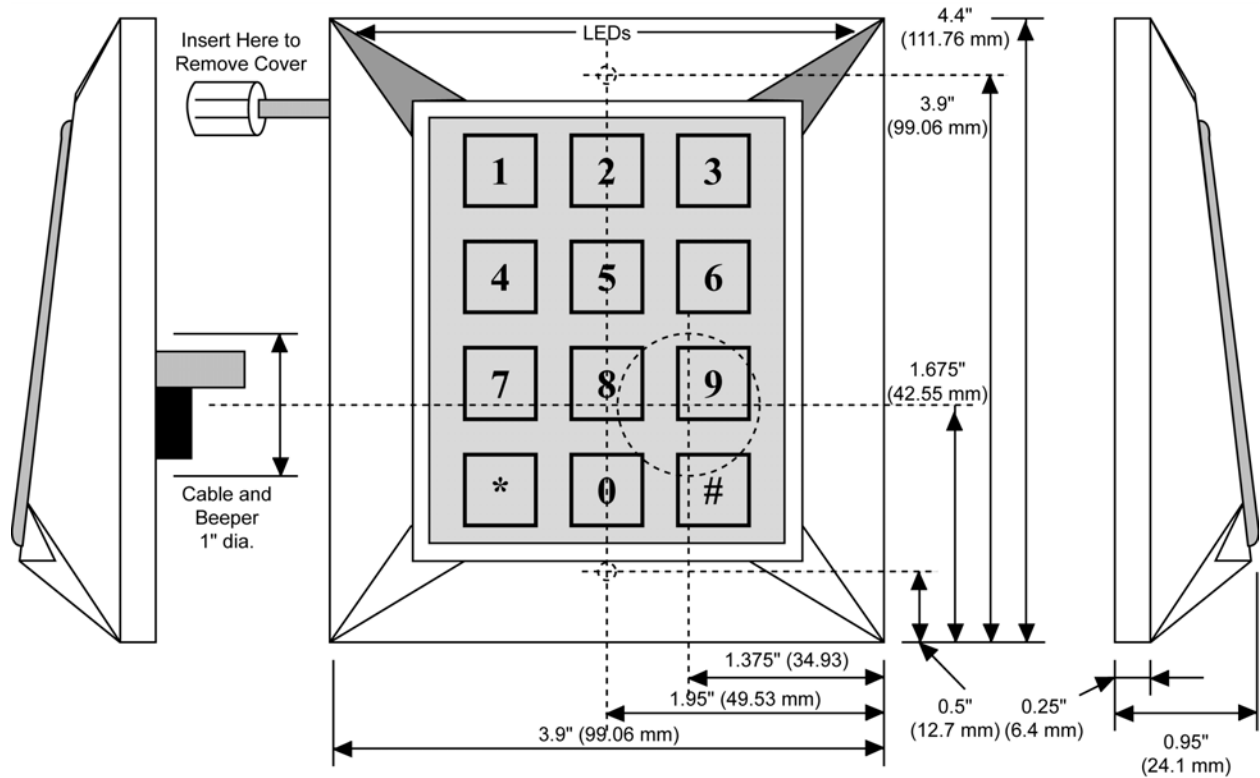
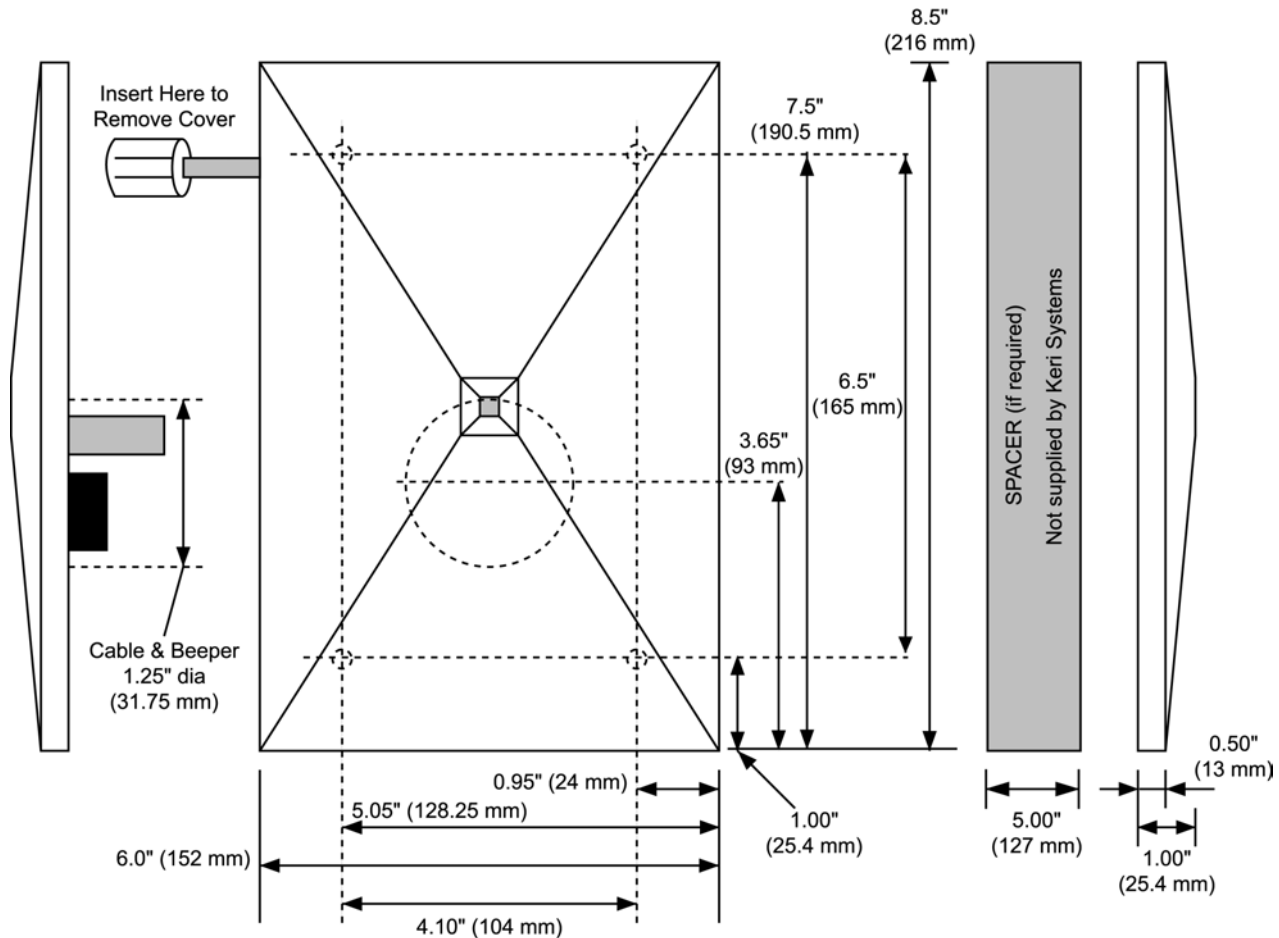

Figure 4: P-600 Mounting Diagram

# Pyramid Series Proximity™ Readers

## 3.5 P-700 Yukon Reader Mounting Instructions

When mounting to a flat surface, five holes need to be drilled to mount the P-700's electronics package (refer to Figure 5). One large hole (1.25 inches - 25.5 mm) accommodates the beeper and reader cable. Four small pilot holes for a #10 countersunk screw (0.190 inches - 4.8 mm) are for mounting the electronics package to a flat wall surface.



**Figure 5: P-700 Mounting Diagram**

If mounting to a metal surface, a spacer that is at least 5 inches (127 mm) thick must be mounted between reader and metal surface. This spacer must be made of a non-metallic material such as plastic.

# Pyramid Series Proximity™ Readers

## 3.6 Installing the Front Cover Bezel

Once the electronics package is installed, simply align one corner of the front cover bezel with the mounted package and gently press it into place. To remove the front cover bezel, slip a thin blade screwdriver just inside the bezel (see the location identified in Figures 1, 3, 4, and 5 for the reader being installed<sup>1</sup>). Gently twist the screwdriver to pop the front cover bezel loose – using excessive force when removing the front cover bezel can damage the reader's LED.

## 3.7 Wiring Connections

Refer to Figures 6, 7, and 8 for instructions for wiring a Pyramid Reader<sup>2</sup> to either a Wiegand reader access panel or a Magnetic Stripe access panel<sup>3</sup>.

*NOTE: As shown in Figures 6, 7, and 8, the shield and ground must be tied together at the access panel. Never tie the shield and ground together at the reader.*

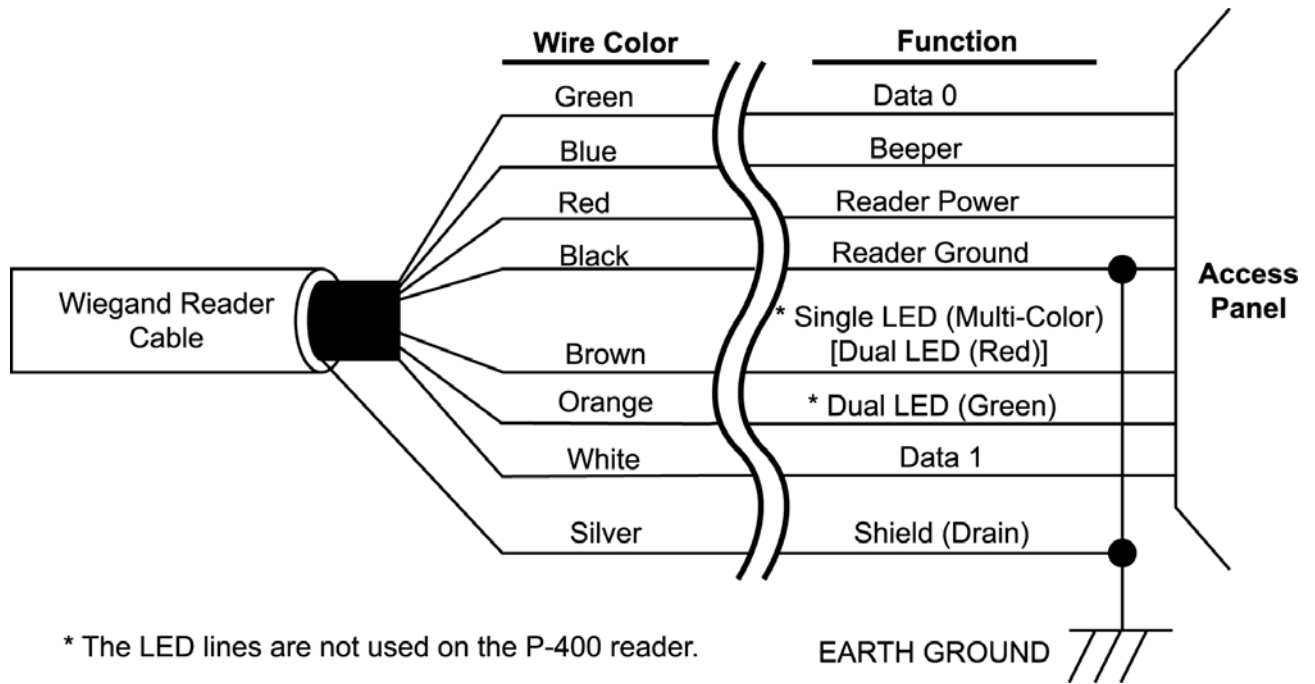

Figure 6: Wiegand Reader Wiring Connections

1. The P-400 Gibraltar Reader does not have a front bezel to maximize its vandal resistance.
2. For Beeper and LED operation information, see section 4.3 Controls on page 12.
3. The magnetic stripe output data configuration is open collector.

# Pyramid Series Proximity™ Readers

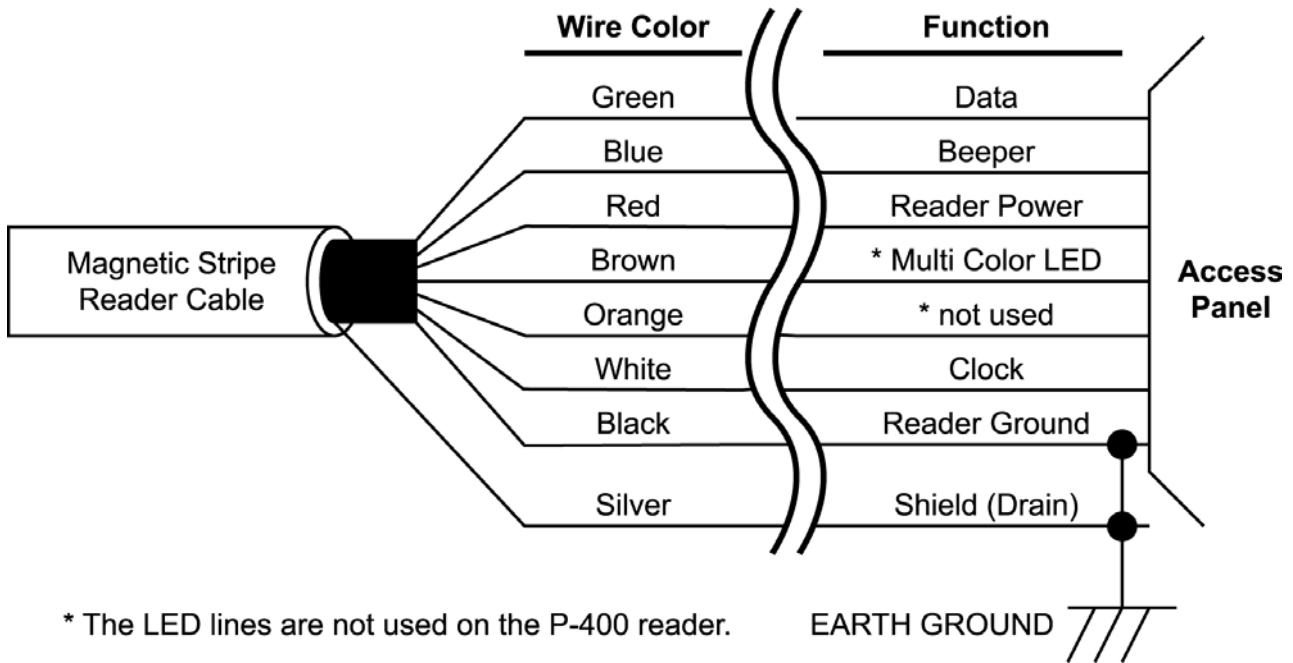

Figure 7: Magnetic Stripe Wiring Connections

Some control panels require a Card Present signal. As the Pyramid Series Proximity readers do not support a card present signal, you may need to add additional circuitry to emulate this signal. Figure 8 provides an example of a circuit diagram using a 47  $\mu$ F capacitor and two 1N4148 diodes, illustrating how a card present signal can be emulated.

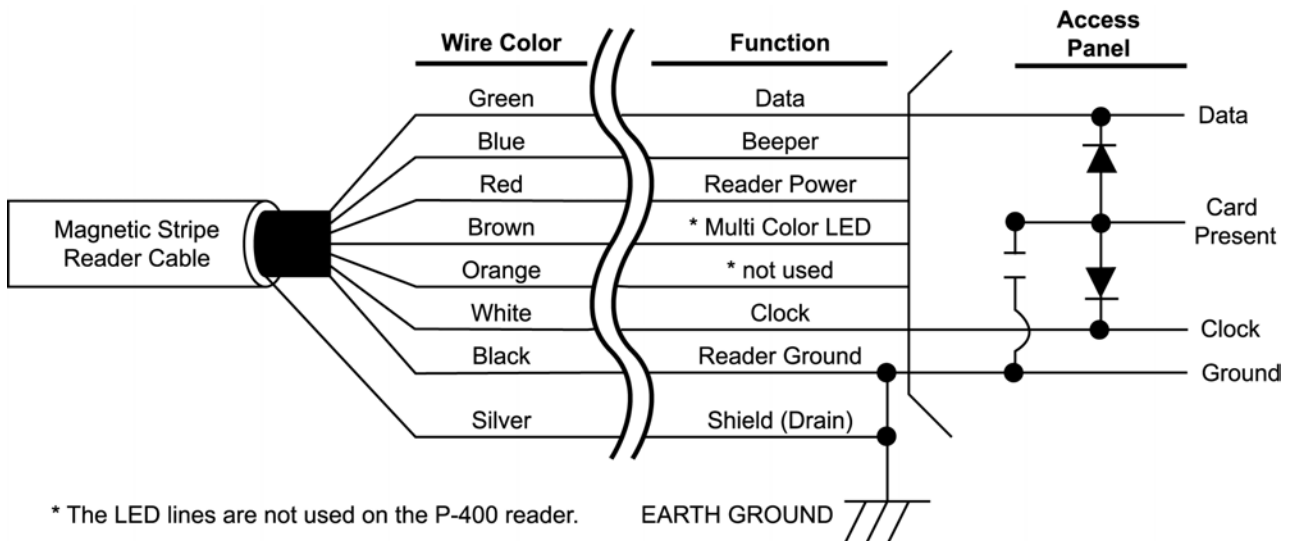

Figure 8: Magnetic Stripe Wiring Connections With Card Present Signal

# Pyramid Series Proximity™ Readers

## 4.0 Installation Verification

The following information applies to an installation with an access panel. Refer to the [Troubleshooting the Reader Installation](#) section beginning on page 17 if the reader is not functioning properly.

### 4.1 Grounding

Shield (Drain) continuity must run from the reader to the access panel. Shield (Drain) and reader ground must be tied together at the access panel and connect to an earth ground in one place.

### 4.2 Power

A reader may be powered by the access panel, so the reader is powered on when the access panel is powered on. However the best case is to power the readers by a separate linear power supply. When powered, verify the voltage at the reader meets the reader's requirements (refer to Table 1 on page 3). When the reader is powered on, its beeper beeps in the following pattern: 3 short beeps, 1 long beep.

### 4.3 Controls

- Beeper (the blue wire): Pull the beeper line low to activate the beeper.
- Single LED<sup>1</sup> Control Line Mode (the brown wire)
  - The normal state is for this line to be high activating the Red LED.
  - Pull the Single LED line low to activate the Green LED.
  - Toggle the Single LED line to activate the Amber LED.
- Dual LED<sup>1</sup> Control Line Mode<sup>2</sup> (the brown and orange wires)
  - The normal state is to pull both LED lines high (brown and orange) to turn the LED Off.
  - Pull both lines low (brown and orange) to activate the Amber LED.
  - Pull the Brown wire high and pull the Orange wire low to activate the Green LED.
  - Pull the Brown wire low and the Orange wire high to activate the Red LED.

### 4.4 Read Range for P-300, P-500, and P-700 Readers

Perform the following steps to verify the read range<sup>3</sup> of P-300, P-500, and P-700 readers (see “Read Range” on page 4 for read range specifications).

1. Hold a Keri Systems Pyramid Series card or tag parallel to the reader, about 6 inches away from the reader.
  - For the P-300 and P-500, hold the card about 6 inches (152 mm) away from the reader.
  - For the P-700, hold the card about 20 inches (508 mm) away from the reader.
2. Slowly bring the Card/Tag in toward the reader and note the distance when the reader recognizes the card (the reader beeps and the LED flashes if it is in default mode).

- 
1. The P-400 Reader does not have an LED to maximize its vandal resistance.
  2. Only Single LED Control Line mode is active when the reader is in Magnetic Stripe mode. The Dual LED Line is not used.
  3. The Reader's read range can be affected by the installation conditions, the material on which the reader is mounted, and whether it is a card or a tag being read. Due to the physical size difference between the coils of various credentials, Multi Technology cards and Key Tags provide less read range than Standard Light Proximity Cards.



# Pyramid Series Proximity™ Readers

## 4.5 Read Range for P-400 Readers

Perform the following steps to verify the read range of P-400 readers (refer to the Read Range specification section on page 4).

1. Hold a Keri Systems Pyramid Series card or tag parallel to the reader, about 3 inches away from the reader.
2. Slowly bring the Card/Tag in toward the reader and note the distance when the reader recognizes the card (the reader beeps).

The metal surrounding and protecting the P-400 reader limits the reader's read range. Because of this, the key tag is the preferred proximity device. Its small size allows the entire key tag to be presented within the reader's read field. Cards can be used, but they must be presented to the reader in a manner that places a large portion of the card within the reader's read field. Figure 9 demonstrates how this is done.

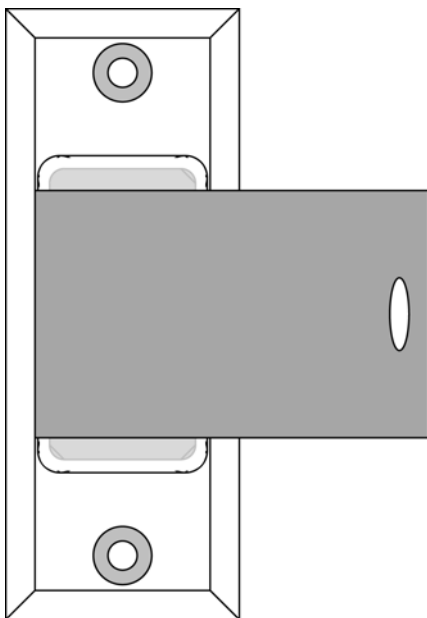

Figure 9: Presenting a Card to a P-400 Reader

# Pyramid Series Proximity™ Readers

## 4.6 Read Range for P-600 Readers

Perform the following steps to verify the read range<sup>1</sup> of P-600 readers (refer to the Read Range specification section on page 4).

1. Hold a Keri Systems Pyramid Series card or tag parallel to the reader, about 6 inches away from the reader.
2. Slowly bring the Card/Tag in toward the reader and note the distance when the reader recognizes the card (the reader beeps and the LED flashes).

The unique construction of the P-600 reader limits the reader's read range. Because of this, Keri Systems recommends presenting a card or key tag to one of the LEDs at the upper corners of the body of the reader. Figure 10 demonstrates how this is done.

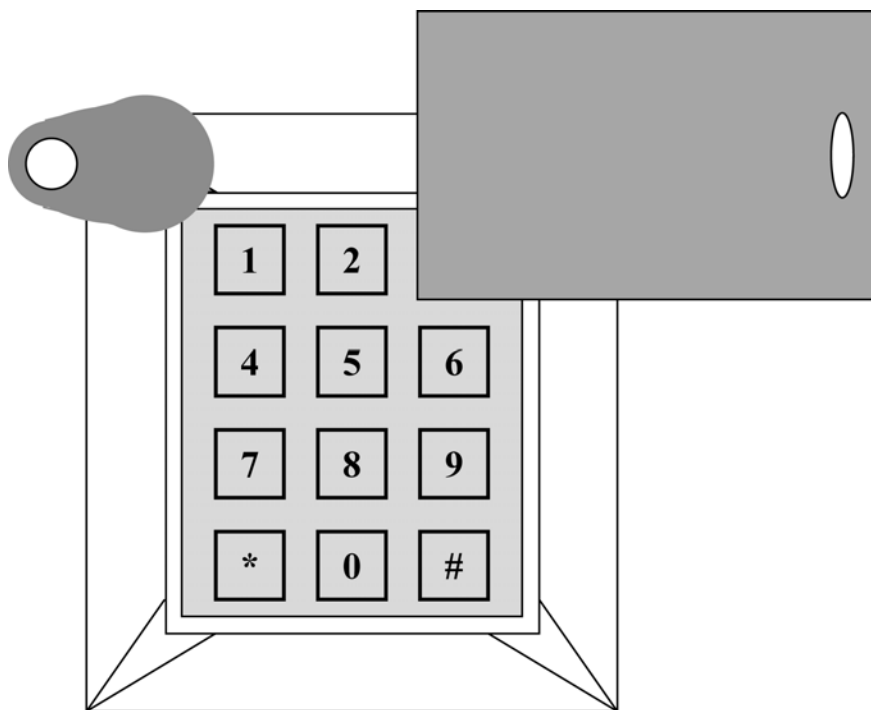

Figure 10: Presenting a Card to a P-600 Reader

1. The Reader's read range can be affected by the installation conditions, the material on which the reader is mounted, and whether it is a card or a tag being read. Due to the physical size difference between the coils of various credentials, Multi Technology cards and Key Tags provide less read range than Standard Light Proximity Cards.

# Pyramid Series Proximity™ Readers

## 4.7 P-600 Keypad Operation

Depress several keys. Each keystroke will generate a beep and an LED flash.

- When in the 8-Bit Burst mode (default), each keystroke sends data to the access panel.
- When in the 26-Bit Wiegand mode, you must press the # key after entering a PIN to send data to the access panel.

## 4.8 P-600 Keypad Error Code (26-bit Wiegand Mode ONLY)

The range for valid keypad entry codes is from 1 to 65534. When the keypad detects an error condition the keypad automatically sends the binary code "1111 1111 1111 1111" - in decimal this number is 65535. This code (binary 1111 1111 1111 1111, decimal 65535) must be reserved for use as an error code. The Essex keypad sends this code to the access panel when one of these three events occurs at the keypad.

1. The # key is pressed without any preceding digits.
2. Any number of 0s are pressed before the # key.
3. Entering the number 65535 or any number greater than 65535.

If an access panel is programmed to accept 65535 as a valid entry code any error condition at the keypad will allow entry.

For security reasons Keri Systems recommends programming the code 65535 into the access control system, assigning this code to an access group that never allows access, and assigning this code the name "KEYPAD ERROR CODE" (or something similar).

## 5.0 Control Cards

Control cards are specially coded proximity cards that toggle readers between specified modes of operation. To toggle between modes, simply present the control card to the reader. The reader beeps and the LED flashes indicating the control card was recognized and the mode has been changed, but no data is sent to the access panel. Please refer to the [Pyramid Series Control Cards Reference Document \(P/N 01846-003\)](#) for further information on how to use control cards. Control cards must be ordered from the supplier: Keri Systems P/N 05287-001.

### 5.1 LED Mode Control Card<sup>1</sup>

Readers can work with access panels configured to drive either Wiegand single or dual LED control line devices. The reader uses the LED Mode control card to change between single and dual line LED control modes. The default setting for the readers is for single LED control line operation.

### 5.2 Beeper Suppress Control Card

When a cardholder presents a card to a Pyramid Series Reader, the reader beeps and flashes to acknowledge the card. The reader uses a Beeper Suppress control card to toggle the reader's beeper ON and OFF. The default setting for the reader is for the beeper to beep to acknowledge card presentation.

### 5.3 LED Suppress Control Card

When a cardholder presents a card to the Pyramid Series Reader, the reader beeps and flashes to acknowledge the card. The reader uses an LED Suppress control card to toggle the reader's LED flash feature ON and OFF. The default setting for the reader is for the LED flash feature to be ON (the LED will flash to acknowledge card presentation).

1. The P-400 Reader does not have an LED to maximize its vandal resistance.



# Pyramid Series Proximity™ Readers

## 5.4 Data Line Test Control Card

Each Pyramid Series Reader has an internal data line test to verify the reader is able to communicate with the access panel. In this test the reader toggles the data lines (either Data 0 and Data 1 for Wiegand configurations or Data and Clock for magnetic stripe configurations) between high and low states: +5 VDC to 0 VDC. This toggling occurs at a slow rate so that it can be viewed on a DVM. The reader uses a "control" card to start or stop the data line test.

## 5.5 Keypad Data Mode Control Card

On the P-600 Rocky Proximity Reader and Keypad, the Wiegand data transmission setting for the keypad is capable of transmitting data in 8-bit burst or Wiegand 26-bit<sup>1</sup>. The keypad uses a Keypad Data Mode control card to change between the 8-bit burst and 26-bit Wiegand data modes. The factory default setting for the keypad portion of the P-600 Rocky Proximity Reader and Keypad is 8-bit burst mode.

## 5.6 Magnetic Stripe Format Lock Control Card

Pyramid readers can transmit data in the format of the presented credential (either magnetic stripe or Wiegand)<sup>2</sup> or can be "locked" so that regardless of the format of the presented credential, the data transmitted to the access panel is always in magnetic stripe format (ABA Track-II, per Dorado's defacto industry standard – using the clock and data line data transfer method). The factory default setting for the Pyramid Readers is for a reader to transmit data in the format of the presented credential.

## 5.7 Wiegand Format Lock Control Card

Pyramid readers can transmit data in the format of the presented credential (either magnetic stripe or Wiegand)<sup>1</sup> or can be "locked" so that regardless of the format of the presented credential, the data transmitted to the access panel is always in Wiegand format. The factory default setting for Pyramid Readers is for a reader to transmit data in the format of the presented credential.

## 5.8 Non-Stop Output Control Card

The reader can be configured so that the reader outputs the data of the presented credential as long as the credential is within the reader's read range. The Non-Stop Output control card changes the reader between sending the output data from a presented credential once or continuously while the credential is within read range. The factory default setting for Pyramid Readers is for a reader to transmit data to the access panel once for each individual credential presentation.

- 
1. The keypad portion of the P-600 outputs data only in a Wiegand format, either the default 8-bit burst format or the optional 26-bit Wiegand format. When the reader portion of the P-600 is fixed in a magnetic stripe output mode, keypad operation is suppressed.
  2. If the reader is configured to be HID compatible and is reading an HID Clock and Data formatted card, the data transmitted will be in Wiegand format.

# Pyramid Series Proximity™ Readers

## 6.0 Troubleshooting the Reader Installation

**Table 3: Reader Installation**

Problem	Possible Cause	Corrective Action
The reader does not recognize a card/tag (no beep, no LED flash).	1. One or more of the reader's wiring connections are incorrect.	<ul style="list-style-type: none"> <li>Power down the reader/access panel and verify the wiring connections are correct for the reader/access panel combination per the instructions in the <u>Wiring Connections</u> section beginning on page 10.</li> </ul>
	2. The reader is not receiving proper power from the access panel.	<ul style="list-style-type: none"> <li>Verify the voltage supplied to the reader is between 5 and 14 VDC.<sup>a</sup></li> </ul>
	3. The reader is mounted too close to a device that radiates electromagnetic interference.	<ul style="list-style-type: none"> <li>Devices such as computer monitors radiate electromagnetic interference that affects read range. When possible, relocate either the reader or the device to provide a greater distance between the two.</li> </ul>
	4. You are using an incorrect type of card.	<ul style="list-style-type: none"> <li>Make sure you are using an access card that is compatible with the reader.</li> </ul>
	5. You are using an incorrect type of card.	<ul style="list-style-type: none"> <li>Make sure you are using an access card that is compatible with the reader.</li> </ul>
The reader has a short read range.	1. The reader/access panel is not properly grounded.	<ul style="list-style-type: none"> <li>Ensure there is a quality earth ground connection made to the access panel. Refer to the access panel's documentation for information regarding the earth ground connection.</li> </ul>
	2. The shield wire for the reader's cable has opened somewhere between the reader and the access panel.	<ul style="list-style-type: none"> <li>Verify the shield line from the access panel to the reader is one continuous, connected line. Refer to the access panel's documentation and verify the shield line is correctly connected to the access panel.</li> </ul>
	3. The reader is mounted too close to a device that radiates electromagnetic interference.	<ul style="list-style-type: none"> <li>Devices such as computer monitors radiate electromagnetic interference that affects read range. When possible, relocate either the reader or the device to provide a greater distance between the two.</li> </ul>
	4. The power supply is generating electromagnetic interference.	<ul style="list-style-type: none"> <li>The power supply on the access panel must be a regulated linear supply – do not use switching supplies as they are often sources electromagnetic interference.</li> </ul>

a. A supply voltage of 12 VDC at the reader is recommended for best operation.



# Pyramid Series Proximity™ Readers

## 6.1 For the P-600 Only

**Table 4: P-600 Installation Only**

<b>Problem</b>	<b>Possible Cause</b>	<b>Corrective Action</b>
Nothing happens when a key is pressed.	1. The reader is not receiving proper power from the access panel.	<ul style="list-style-type: none"> <li>Verify the voltage supplied to the reader is between 5 and 14 VDC.<sup>a</sup></li> </ul>
Nothing happens after a PIN is pressed.	1. The # key (send) was not pressed after the code was entered.	<ul style="list-style-type: none"> <li>Reenter the code and then press the # key.</li> </ul>

a. A supply voltage of 12 VDC at the reader is recommended for best operation.