

# Eight-Door Concentrator

Keri Systems KDC-8 Eight-Door Concentrator places four controllers into one cabinet, reducing the amount of space needed to mount four controllers. The concentrator is designed to fit in a standard IT server/telecom rack, but can easily be wall mounted. There are knock-outs around the outside of concentrator's enclosure for cable routing.

## 1.0 Unit Specifications

- Height – 15 inches (plus 0.25 inches for the cover)
- Width – 17 inches (plus 0.25 inches for the cover)
- Depth – 6.5 inches (plus 0.25 inches for the cover)
- Weight – 19 pounds (including controllers and satellite boards, NOT including cabling)
- Power Requirements – 12 VDC @ 3 A for the concentrator cabinet, including four, two-door controllers.

*NOTE: Separately powered door lock power requirements depend upon the door locks being used. Please ensure sufficient power is provided to support all door locks connected to the cabinet.*

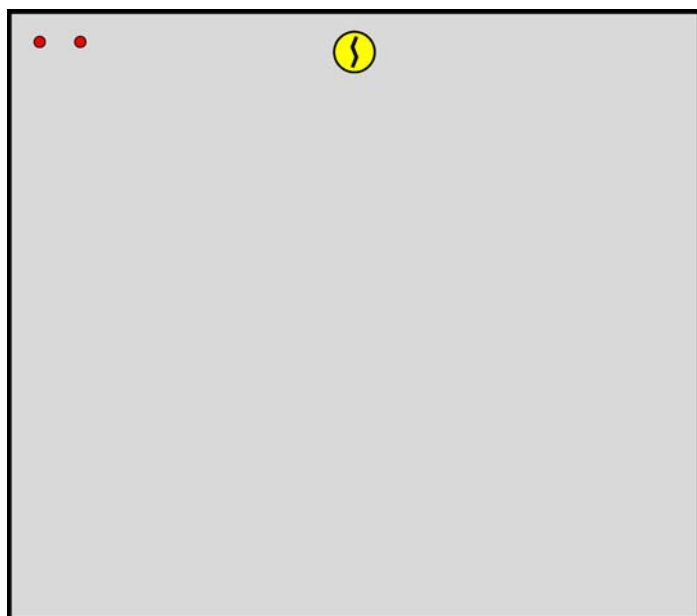

Figure 1: 8-Door Concentrator Enclosure

## 2.0 Mounting the Cabinet

There are three methods of cabinet mounting.

1. wall mounting through the rear of the cabinet
2. wall mounting using the rack brackets
3. rack mounting to a standard IT Server/Telecom rack



# Eight-Door Concentrator

## 2.1 Through the Cabinet Mounting

The easiest mounting method is wall mounting through mounting holes within the cabinet. There are three key-hole screw slots and three screw through-holes for secure mounting. Have an assistant hold the unit in the desired mounting place and mark the mounting locations, see Figure 2 (if there are controllers in the cabinet, please remove them before mounting the enclosure). Drill pilot holes in the marked locations and then install the unit.

*Note: When fully loaded, the unit weighs 19 pounds (before cabling). Mount the unit securely against the wall using molly-bolts or by securing at least two mounting screws to a wall stud.*

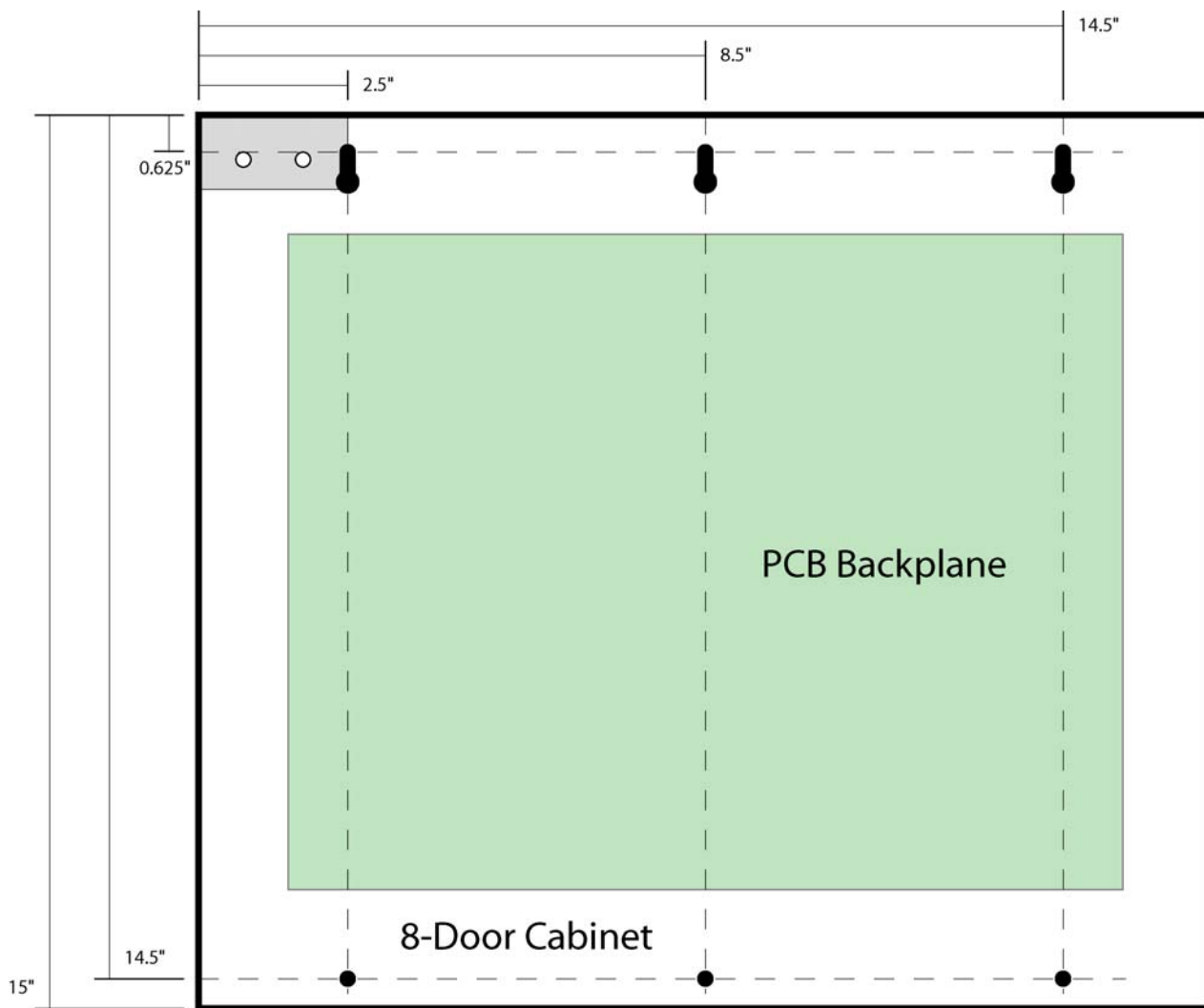

**Figure 2: Through-the-Cabinet Mounting Dimensions**



# Eight-Door Concentrator

Have an assistant hold the unit in the desired mounting place and mark the mounting locations (see Figure 4). Drill pilot holes in the marked locations and then install the unit.

*Note: When fully loaded, the unit weighs 19 pounds (before cabling). Mount the unit securely against the wall using molly-bolts or by securing at least two mounting screws to a wall stud.*

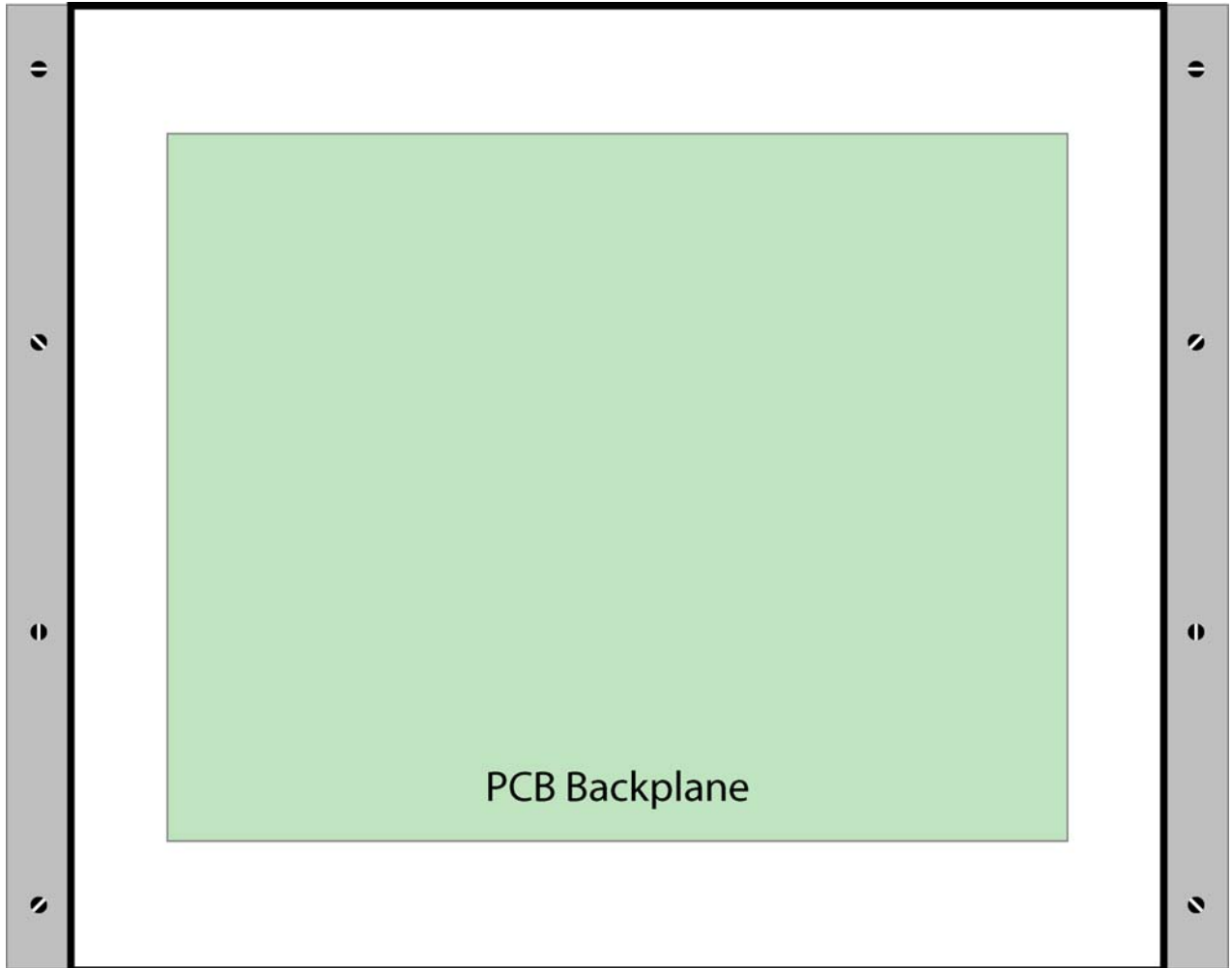

**Figure 4: Wall Mounting the Enclosure Using the Brackets**

# Eight-Door Concentrator

## 2.3 Rack Mounting

The cabinet is designed to be installed in a standard IT Server/Telecom rack using the two rack-mount brackets. Attach the brackets to the sides of the cabinet (see Figure 5).

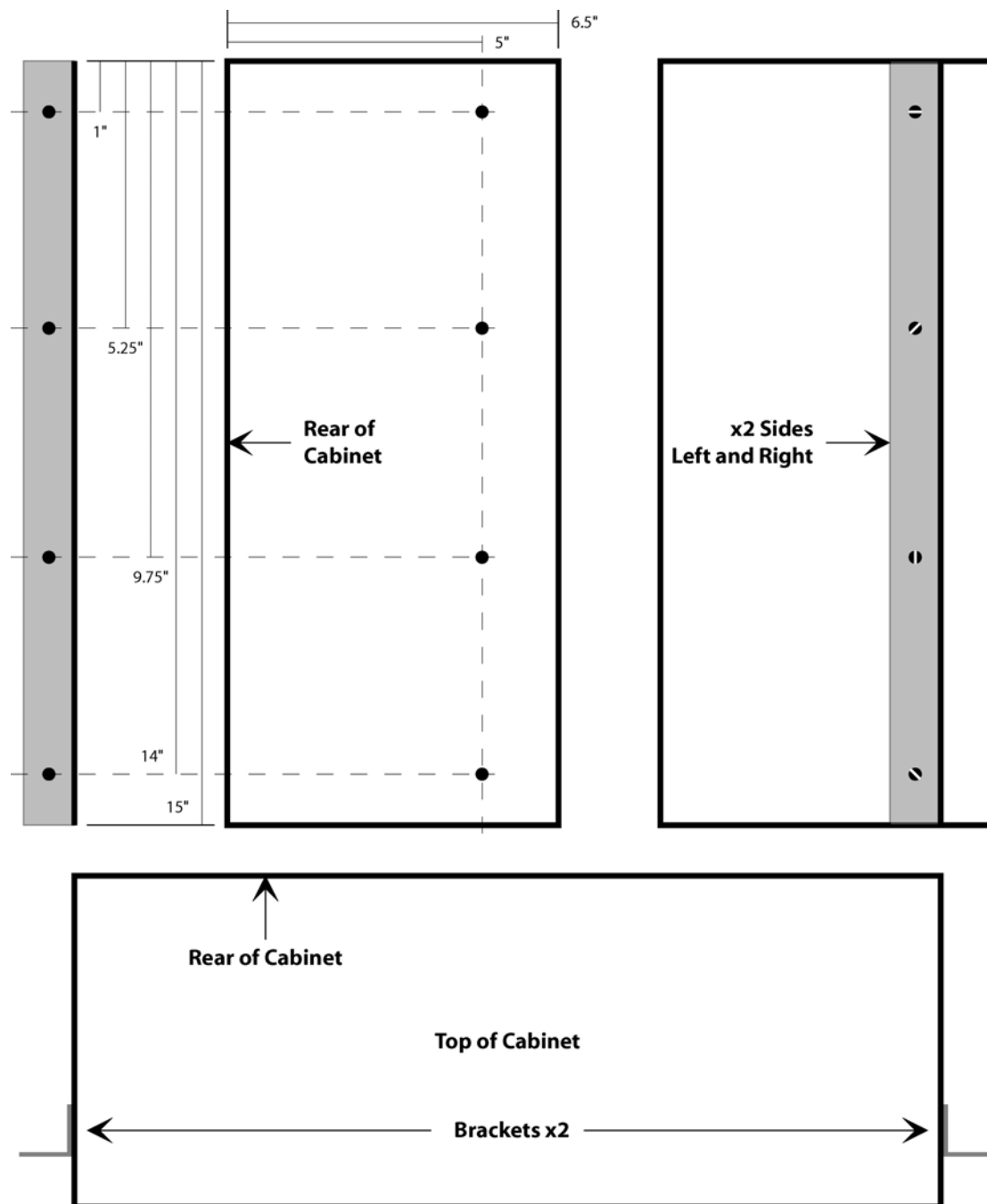

Figure 5: Attaching the Brackets to the Enclosure for Rack Mounting

# Eight-Door Concentrator

Have an assistant hold the cabinet in the desired mounting place on the rack and secure the cabinet using the rack mount screws (see Figure 6 and Figure 7 – a generic rack configuration is shown, your rack may be slightly different).

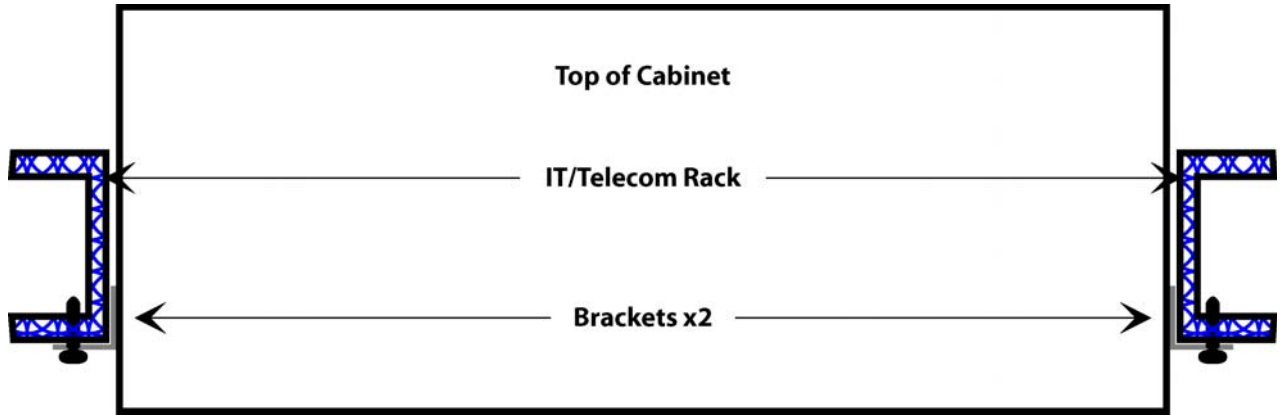

Figure 6: Attaching the Unit to the Rack - Top View

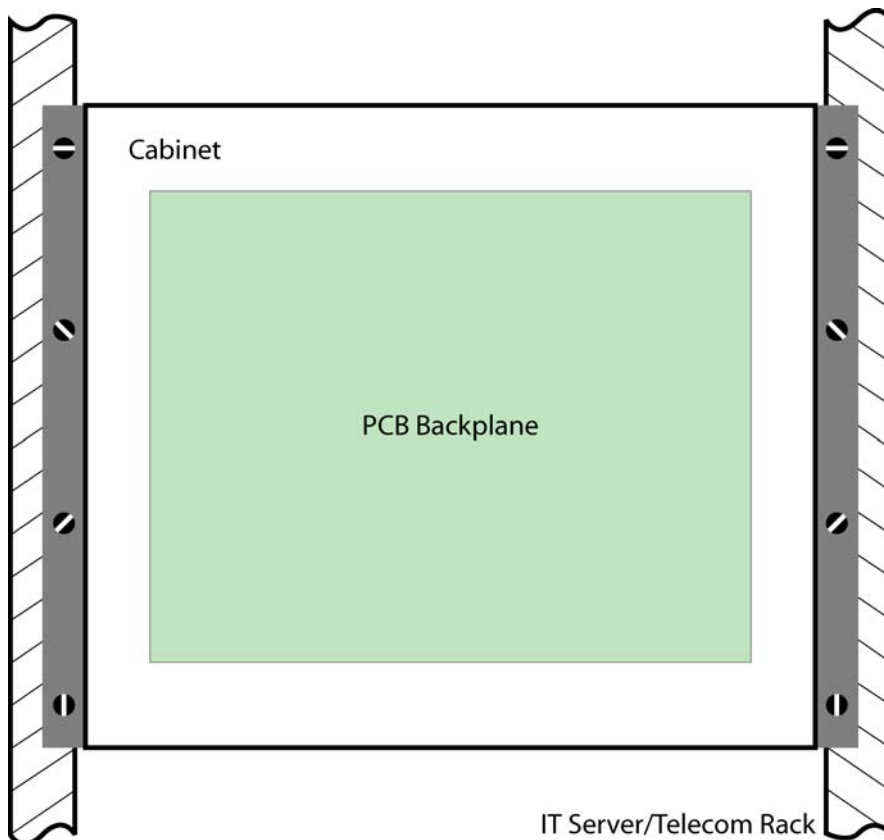

Figure 7: Attaching the Unit to the Rack - Front View

# Eight-Door Concentrator

## 3.0 Configuration and Wiring

It takes a lot of cabling to support all eight doors in the cabinet. Knockouts are provided on all four sides, cabinet providing maximum flexibility for routing cables.

Cabinet configuration is kept simple. The only jumpers of which to be aware are the external door lock power jumpers, and there are two front-cover LED cables.

### 3.1 External Door Lock Relays

The 8-door cabinet is designed to allow the door lock relays to operate in two ways.

1. Non-powered/dry-contact for use with devices such as a gate operator or as a non-powered general purpose output.
2. Powered through the lock relay common for electric door locks. The unit can use one power supply to drive both the controllers and the lock relays, or have separate power supplies, one for the controllers and one for the door lock relays.

Each door lock relay can be set according to your application: non-powered/dry-contact or powered for an electric door lock.

*NOTE: When providing power for door lock relays, Keri strongly recommends using two separate power supplies. This isolates controller power from the transients that can be created on the lock power line as the door relays kick on and off. This will reduce controller interference.*

The factory default is to have the following jumpers set per Table 1, allowing the use of external lock power through the relay common. Refer to Figure 8 on page 8 for jumper locations.

Jumpers listed in Table 1 **must** be removed for any controller/satellite board relays used in non-powered/dry-contact mode or in non-powered, general purpose output mode.

**Table 1: External Door Lock Power Jumpers**

Controller	A-Door	B-Door
Slot 1	J47	J44
Slot 2	J51	J50
Slot 3	J56	J55
Slot 4	J59	J58



# Eight-Door Concentrator

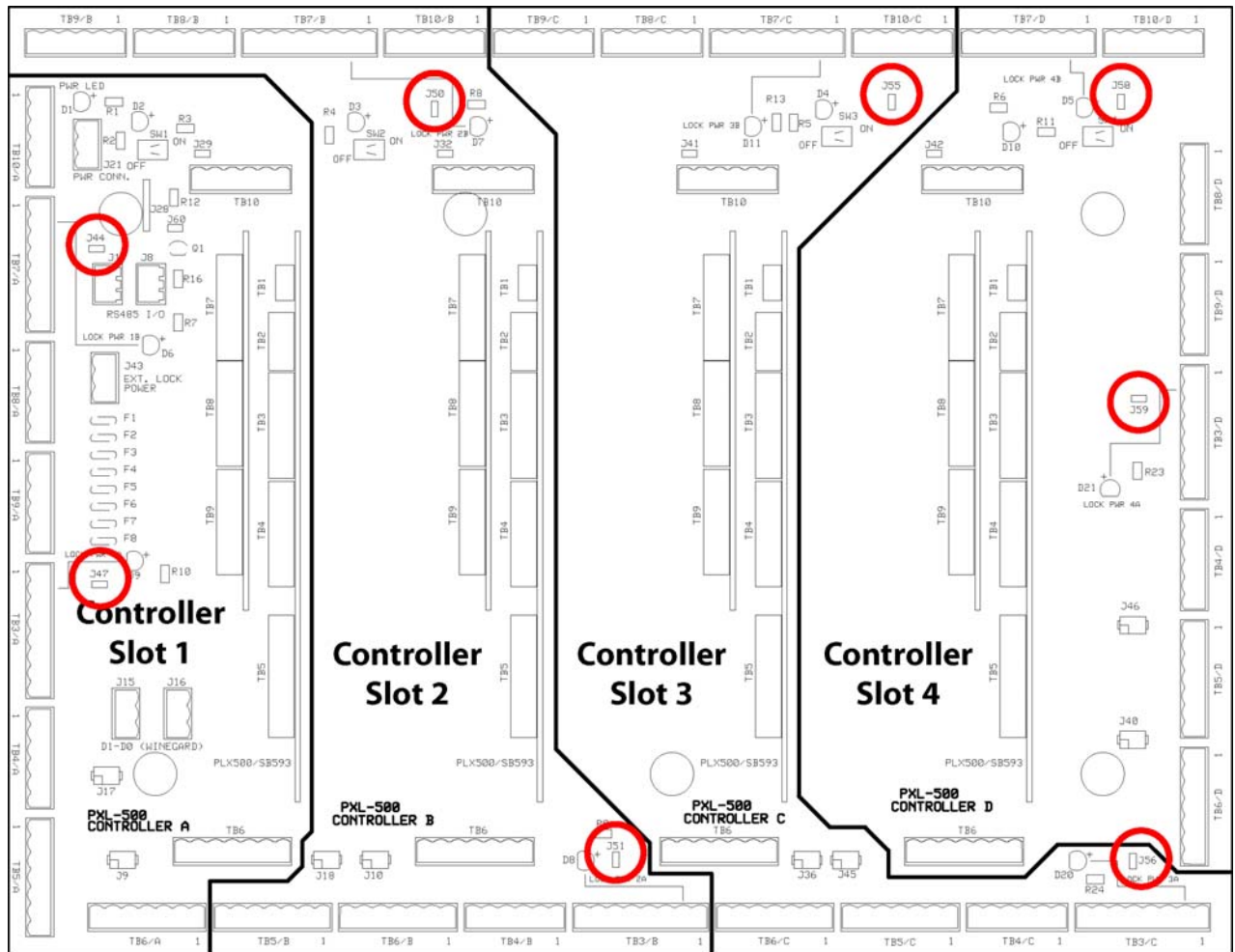

Figure 8: External Door Lock Power Jumpers

# Eight-Door Concentrator

## 3.2 Cabinet Cover Power LED

The cabinet cover Power LED cable is connected at the factory. It is the left LED on the face of the cabinet (see Figure 1 on page 1). Should the cable come free, connect the cable to J28 pins 1 and 2 with the RED wire connected to pin 1. Refer to Figure 9.

## 3.3 Cabinet Cover Data LED

The cabinet cover Data LED cable is connected at the factory. It is the right LED on the face of the cabinet (see Figure 1 on page 1). Should the cable come free, connect the cable to J60 pins 1 and 2 with the RED wire connected to pin 1. Refer to Figure 9.

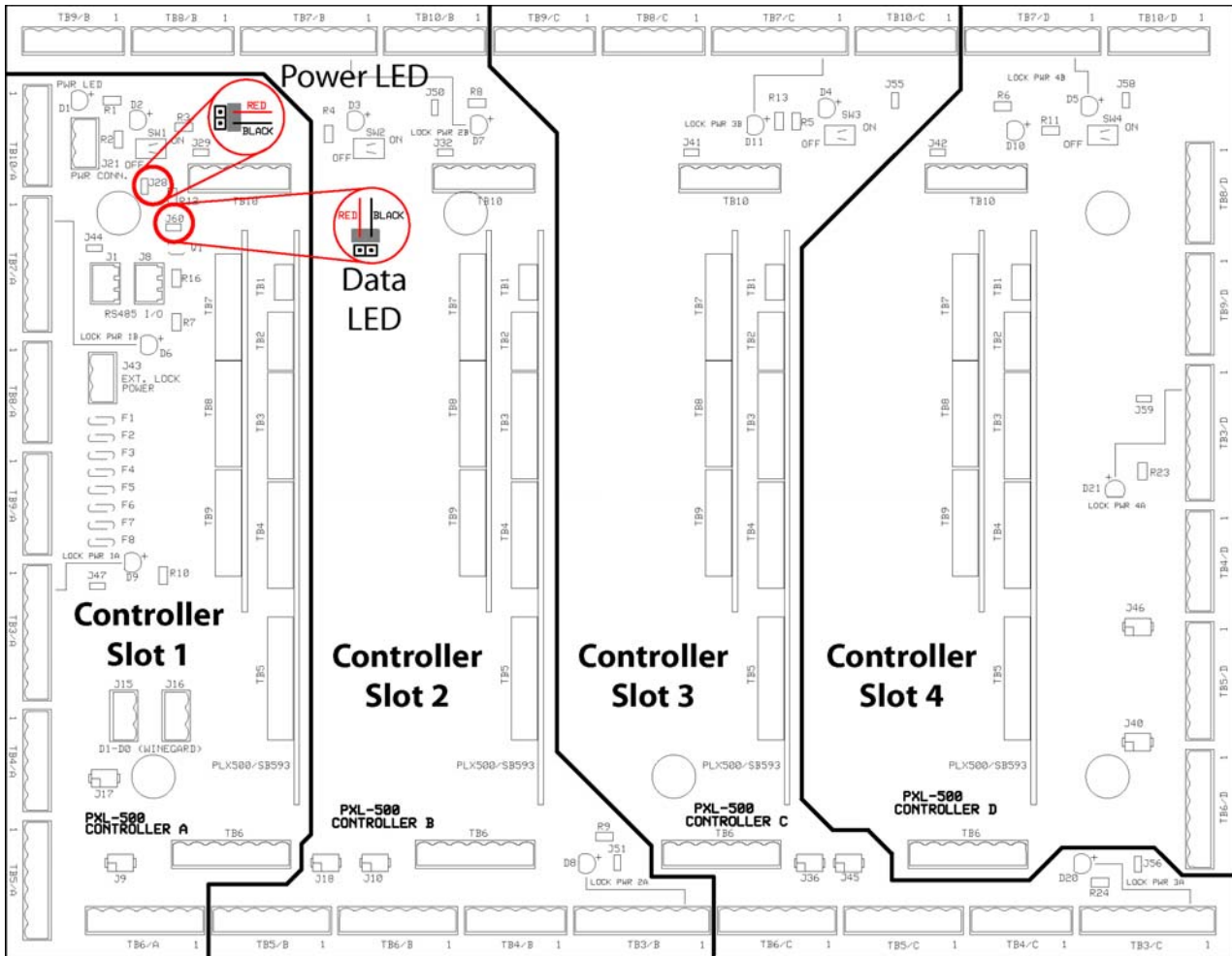
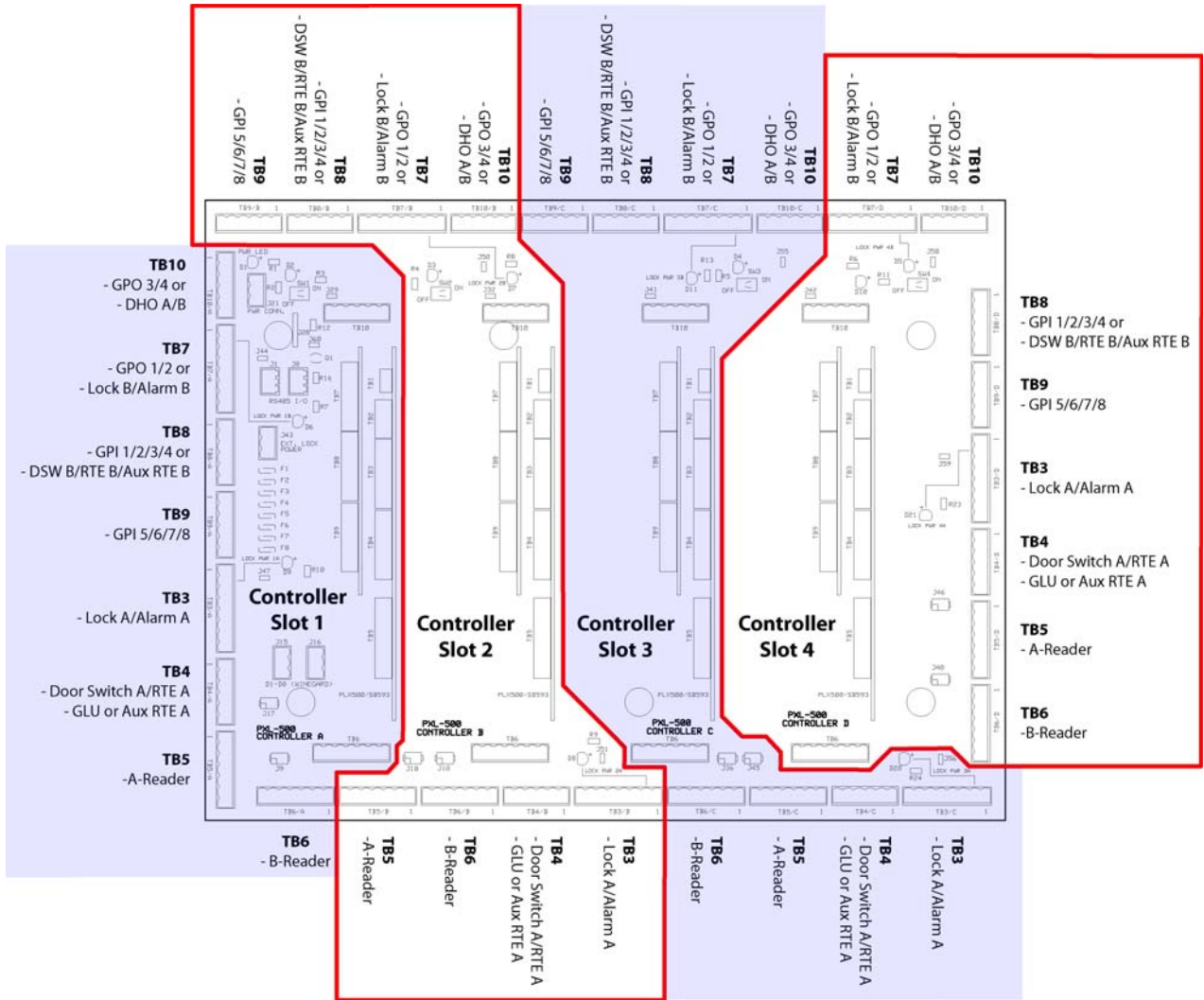

**Figure 9: Power and Data Cover LED Cabling**

# Eight-Door Concentrator

## 3.4 Individual Controller Wiring Connections

Around the perimeter of the PCB is a ring of 32 connectors. Each connector on the four controllers/satellite boards has a corresponding connector on the perimeter ring – eight connectors for each controller/satellite board. Figure 10 shows the location of the connector set for each controller/satellite board.



**Figure 10: Connector Set per Controller/Satellite Board**

# Eight-Door Concentrator

## 3.4.1 A-Reader, B-Reader (TB5 and TB6)

Controllers will either be Keri Proximity (PXL-500P - see Figure 11) or Wiegand (PXL-500W - Figure 12). Make the wiring connections from the Reader to the appropriate connector accordingly: A-Reader to TB5, B-Reader to TB6. Use Figure 10 on page 10 to locate the correct connector locations for each controller.

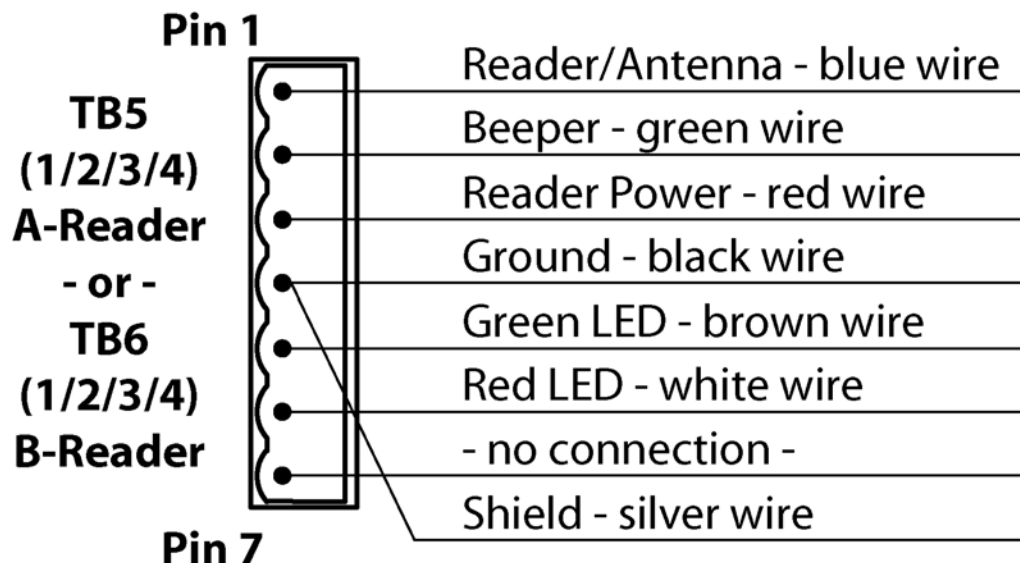
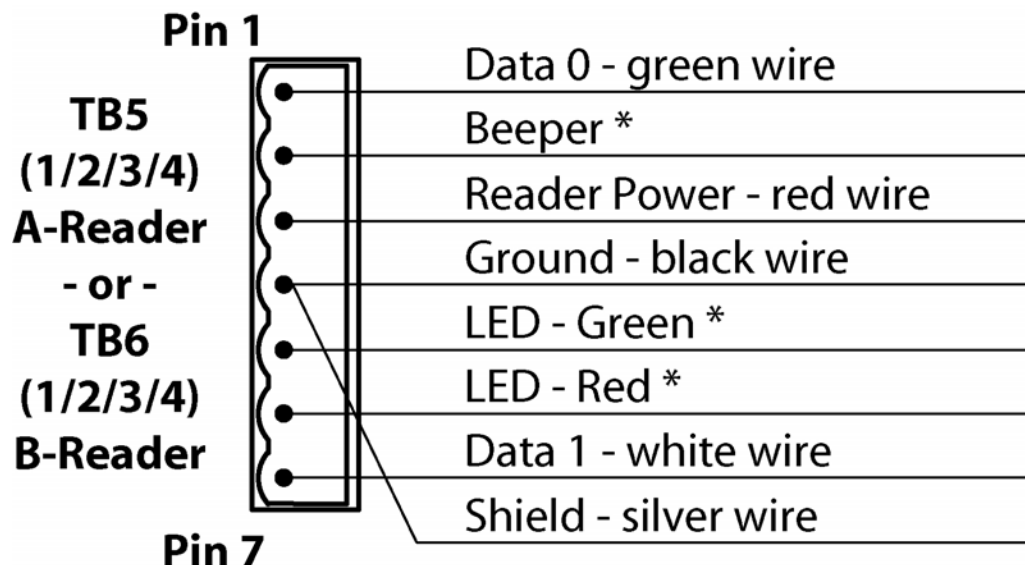

Figure 11: Proximity A-Reader and B-Reader Connections (TB5 and TB6)



\* Refer to Reader documentation for wire color

Figure 12: Wiegand A-Reader and B-Reader Connections (TB5 and TB6)



# Eight-Door Concentrator

## 3.4.2 A-Door: Lock Relay, Alarm Relay Outputs (TB3)

Make the wiring connections for the A-Door Lock and Alarm Relays (TB3). Use Figure 10 on page 10 to locate the correct connectors for each controller.

For the Lock Relay, power is applied to the common line. This provides flexibility, allowing you to provide power to the lock depending upon the type of lock you have.



Figure 13: A-Door Lock Relay and Alarm Relay Connections (TB3)

# Eight-Door Concentrator

## 3.4.3 B-Door: Lock Relay, Alarm Relay, General Purpose Outputs 1 and 2 (TB7)

TB7 can serve one of two purposes depending upon the configuration of the controller's satellite board: as the B-Door Lock Relay and Alarm Relay OR as general purpose outputs 1 and 2. Make the wiring connections for either Lock/Alarm Relay usage or for general purpose outputs (TB7). Use Figure 10 on page 10 to locate the correct connectors for each controller.

For the Lock Relay, power is applied to the common line. This provides flexibility, allowing you to provide power to the lock depending upon the type of lock you have.

*NOTE: If the controller is configured for TB1 general purpose output 1 operation, the corresponding door lock relay jumper may need to be removed (see Table 1 on page 7 for jumper identification). Remove the jumper for non-powered/dry-contact operation; leave the jumper in place for powered operation.*



**Figure 14: B-Door Lock Relay and Alarm Relay Connections**

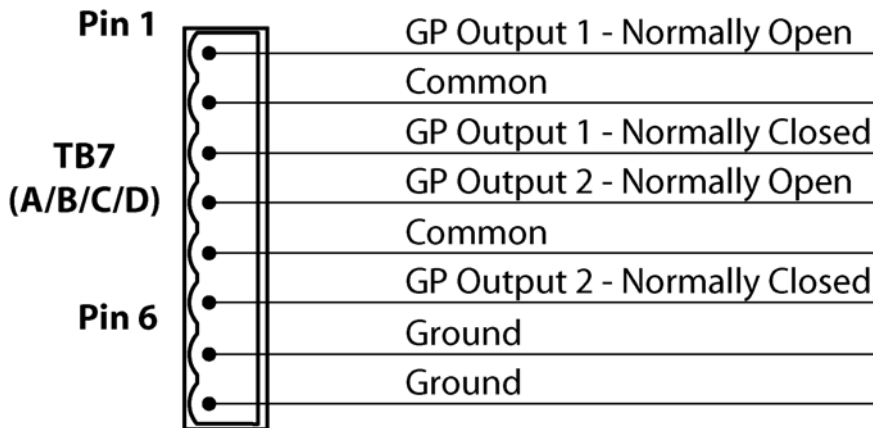
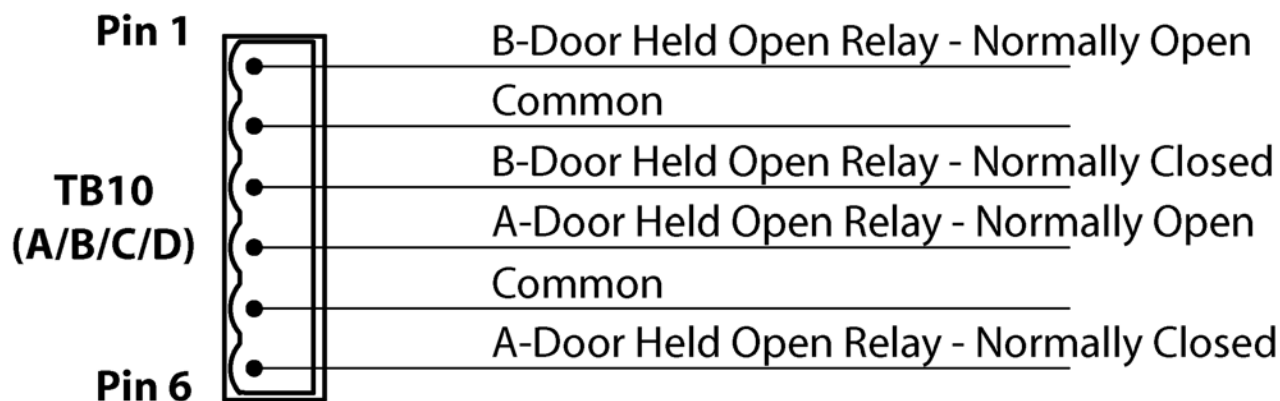

**Figure 15: General Purpose Output 1 and 2 Connections (TB7)**

# Eight-Door Concentrator

## 3.4.4 A and B-Door Held Open Outputs, General Purpose Outputs 3 and 4 (TB10)

TB10 can serve one of two purposes depending upon the configuration of the controller's satellite board: as the A and B Door Held Open Outputs OR as general purpose outputs 3 and 4. Make the wiring connections for either Door Held Open Relay usage or for general purpose outputs as required. Use Figure 10 on page 10 to locate the correct connectors for each controller.



**Figure 16: A and B Door Held Open Outputs**

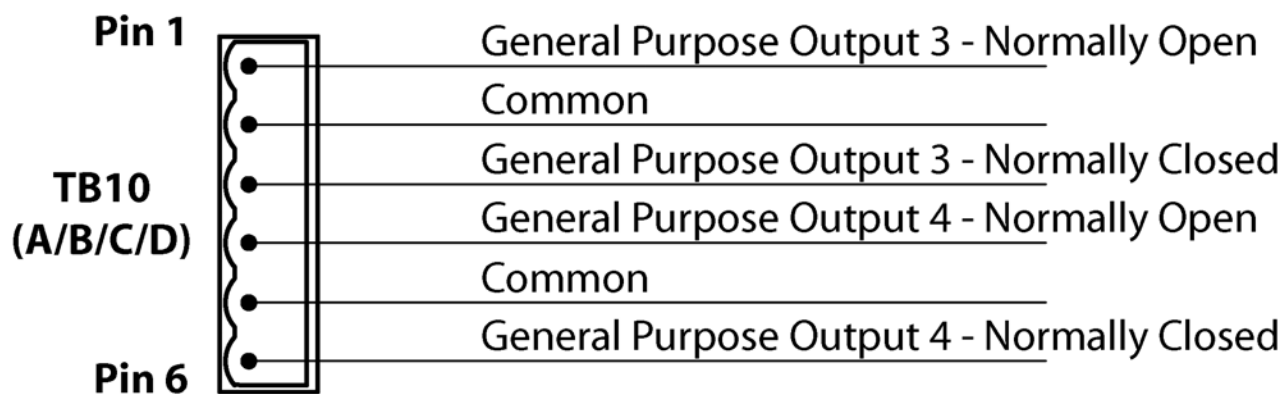

**Figure 17: General Purpose Outputs 3 and 4**

*NOTE: When wired correctly, all door held open outputs can provide voltage to drive an external device.*

# Eight-Door Concentrator

## 3.4.5 A-Door: Status Switch, Request to Exit, Auxiliary Request to Exit, Global Unlock Inputs (TB4)

Make the wiring connections for the A-Door Status Switch and Request to Exit inputs (TB4). Use Figure 10 on page 10 to locate the correct connectors for each controller.

On the master controller, the final input on TB4 can serve one of two purposes. It can either act as an Auxiliary Request to Exit for the A-Door or as a Global Unlock for the access control system. For the master controller, determine if your site requires a Global Unlock input or if you need the Auxiliary Request to Exit input, and make the appropriate wiring connection.

For all other controllers, the final input can only be used as an Auxiliary Request to Exit for the A-Door. Make the Auxiliary Request to Exit connection if required.

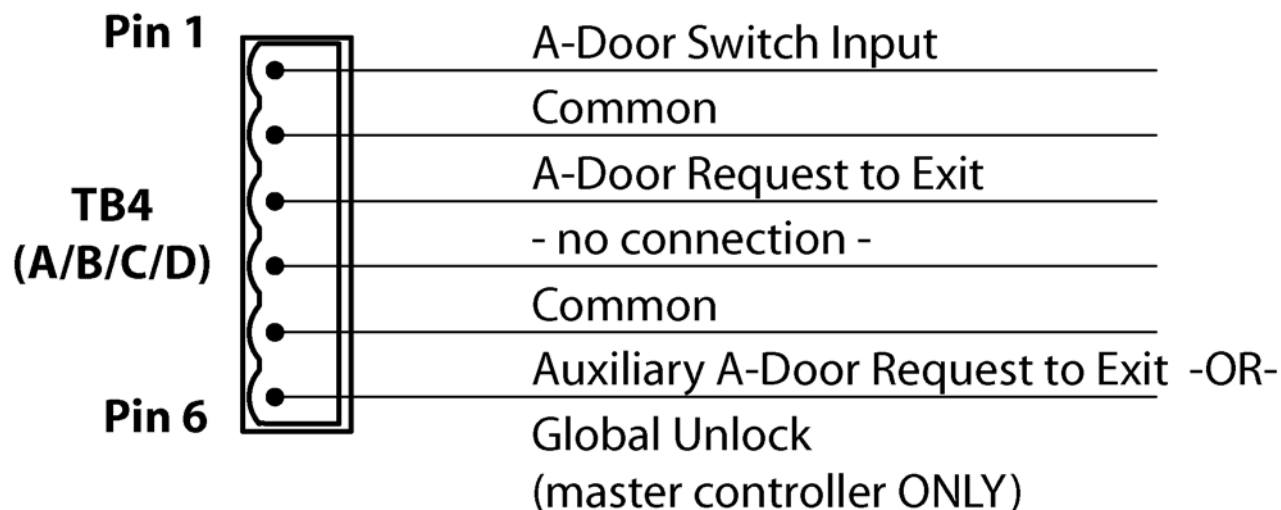
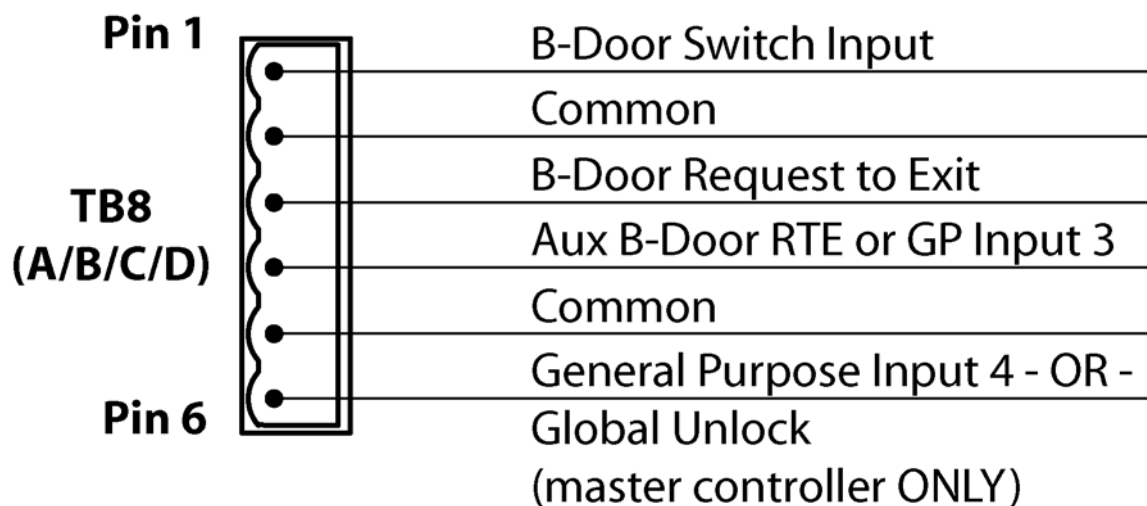

Figure 18: A-Door: Status Switch, Request to Exit, Auxiliary Request to Exit, Global Unlock Inputs (TB4)

# Eight-Door Concentrator

## 3.4.6 B-Door: Status Switch, Request to Exit, Auxiliary Request to Exit, General Purpose Input 4 (TB8)

Make the wiring connections for the B-Door Status Switch, Request to Exit, and Auxiliary Request to Exit inputs (TB8). Make the general purpose input 4 connection if required. Use Figure 10 on page 10 to locate the correct connectors for each controller.



**Figure 19: B-Door: Status Switch, Request to Exit, Auxiliary Request to Exit, General Purpose Input 4 (TB8)**

# Eight-Door Concentrator

## 3.4.7 General Purpose Inputs 5, 6, 7, 8 (TB9)

Make the general purpose input 5, 6, 7, and 8 connections if required (TB9). Use Figure 10 on page 10 to locate the correct connectors for each controller.

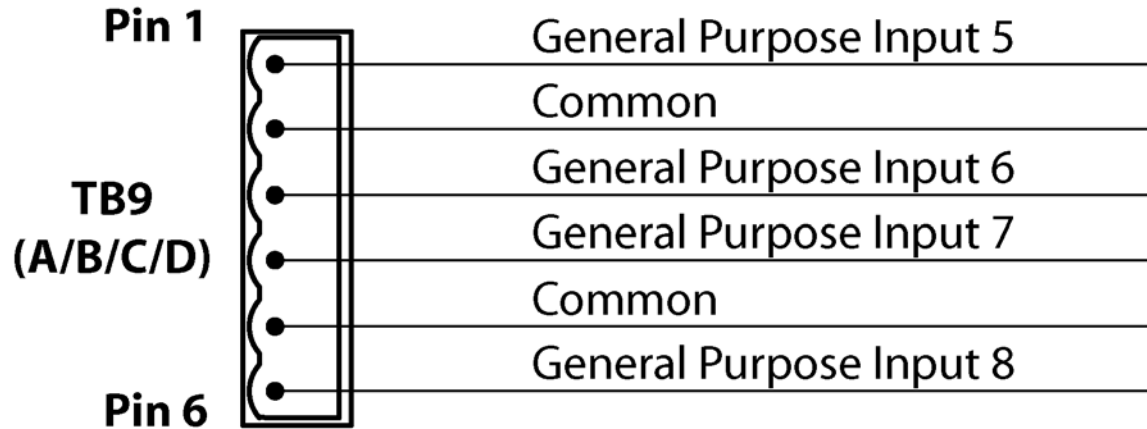

Figure 20: General Purpose Inputs 5, 6, 7, and 8

# Eight-Door Concentrator

## 3.5 RS-485 Network

J1 and J8 allow you to daisy-chain the RS-485 access control network (see Figure 21). Connect the incoming RS-485 line to J1 and connect the outgoing RS-485 line to J8 (see Figure 22).

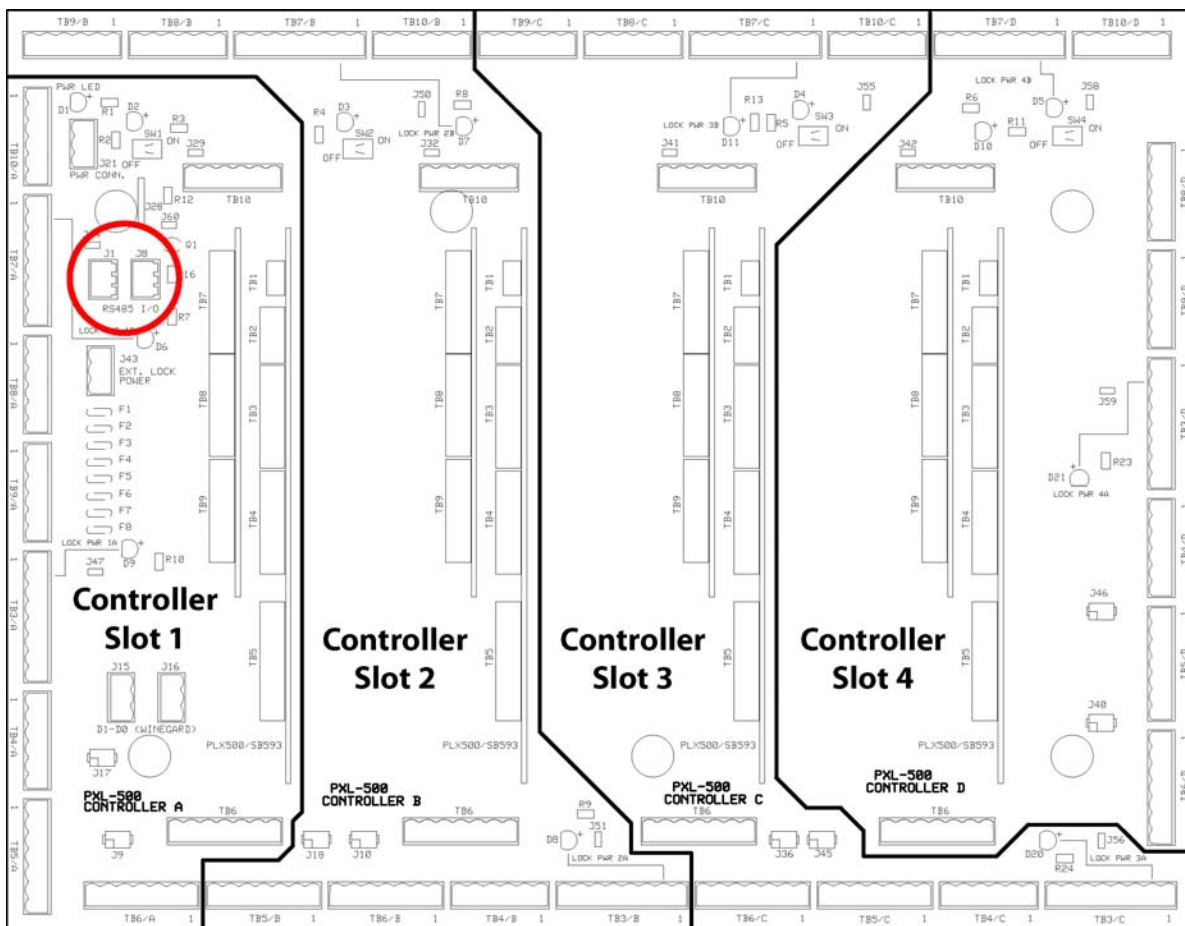

Figure 21: Location of RS-485 Network Connectors

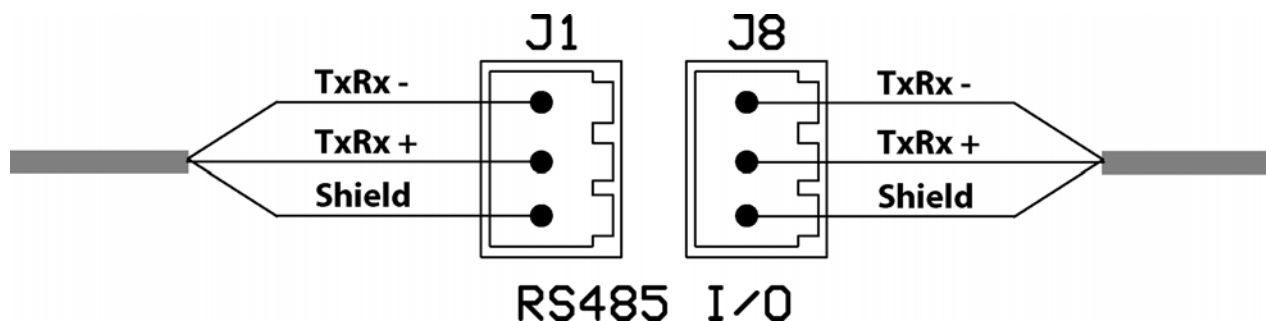

Figure 22: RS-485 In/Out Lines

# Eight-Door Concentrator

## 3.6 External Door Lock Power

J43 provides the external door lock power (see Figure 23). Connect the line from the power supply to J43 (see Figure 24). Power can be from an independent power supply or can be daisy-chained from the controller/cabinet power supply (Section 3.7 on page 20). Power is provided to the relays through the lock relay common line.

*NOTE: When providing power for door lock relays, Keri strongly recommends using two separate power supplies. This isolates controller power from the transients that can be created as the door relays kick on and off.*

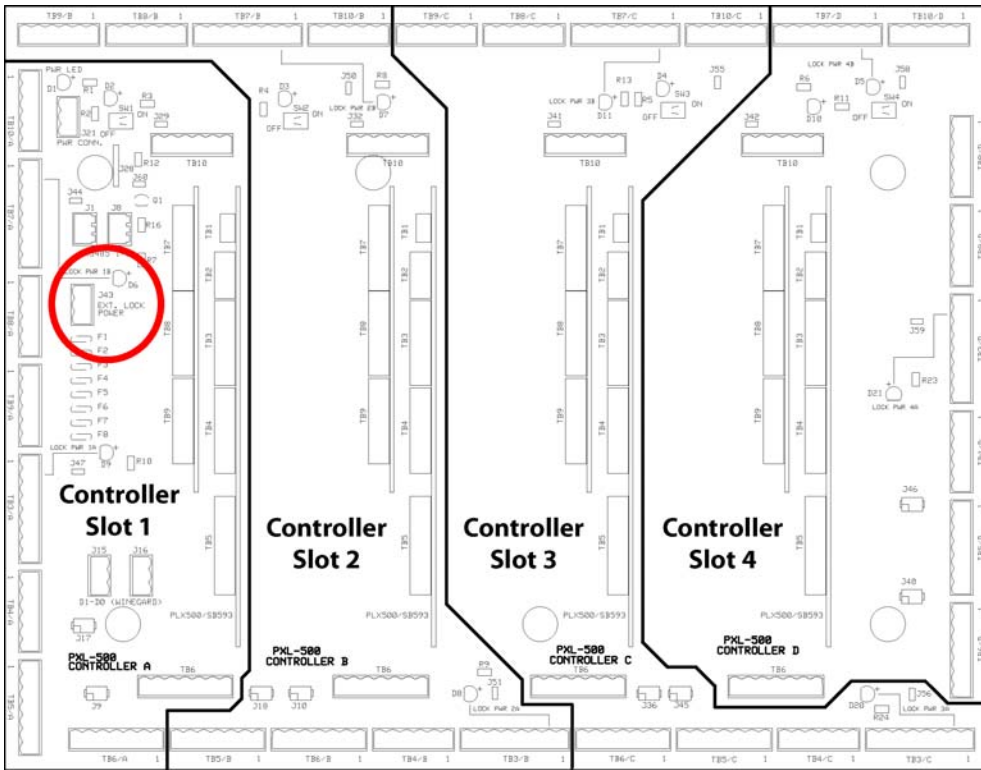

Figure 23: Location of Lock Power Connector

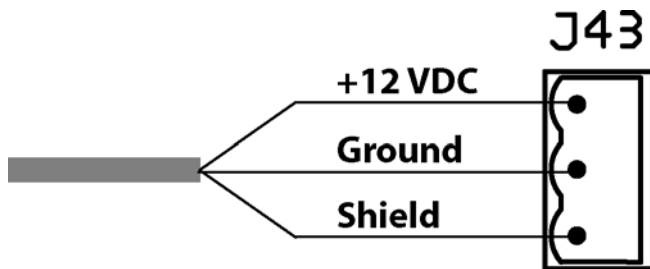

Figure 24: Lock Power Wiring



# Eight-Door Concentrator

## 3.7 Cabinet Power

J21 provides power to the controllers (see Figure 25). Connect the line from the controller power supply to J21 (see Figure 26).

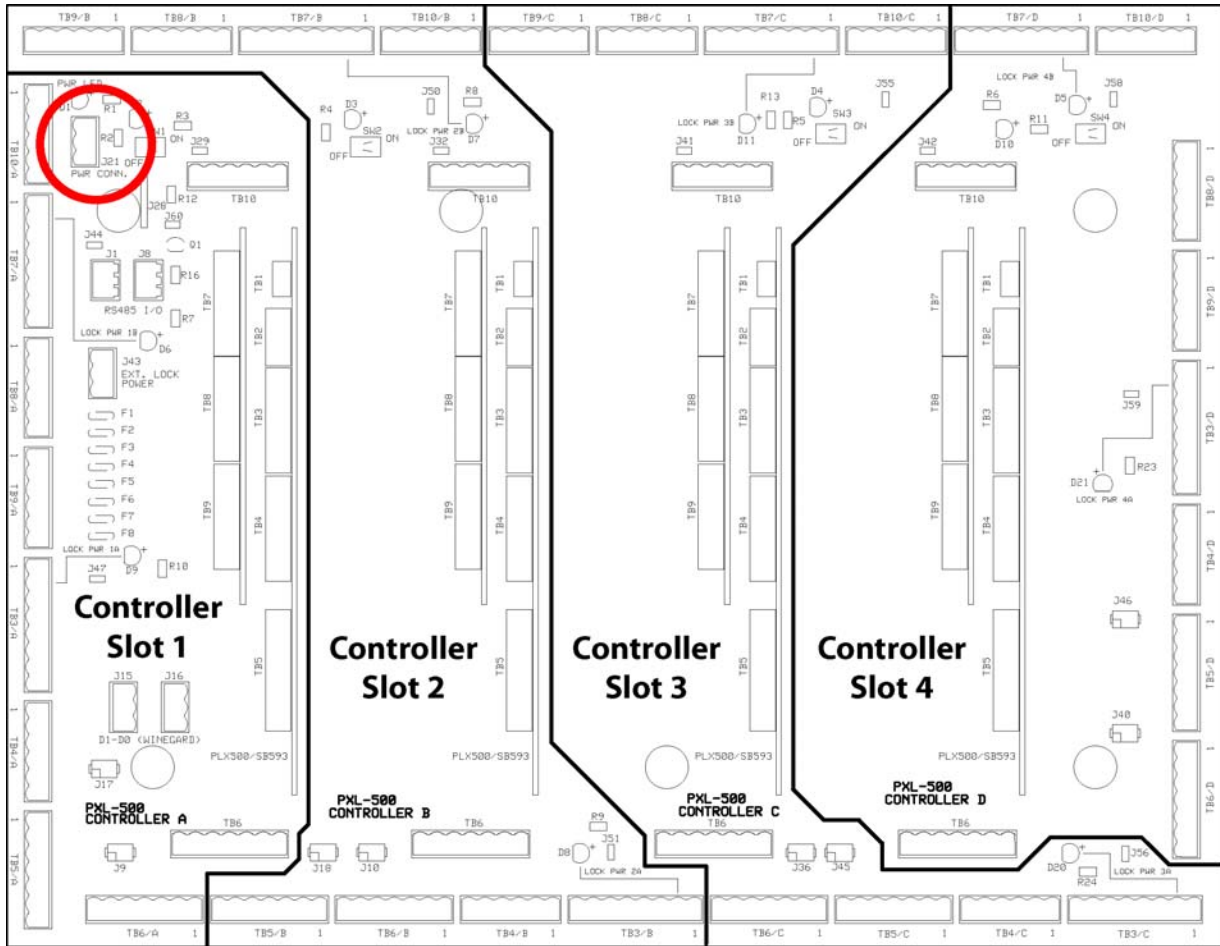

Figure 25: Location of Controller Power Connector

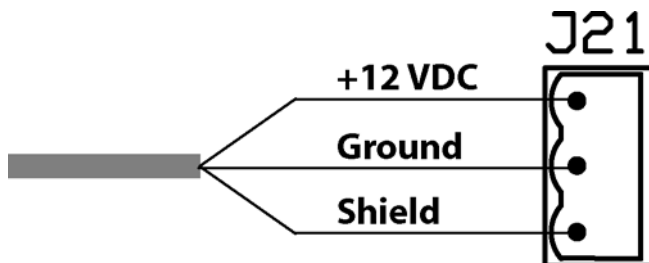

Figure 26: Controller Power Wiring

# Eight-Door Concentrator

## 4.0 Inserting PCBs

The concentrator backplane is now ready for the four controllers/satellite boards. To insert a controller into the backplane, carefully align the connectors on the controller with the plugs on the backplane and slide the controller into place. It will be a firm, snug connection.

Once all four controllers are installed, connect the four Reader Jumper cables (provided with the cabinet). These cables connect the B-Reader on the controller to the backplane.

Next, connect the TB10 Relay Jumper cables (provided with the cabinet). These cables connect TB10 on the satellite board to the backplane.

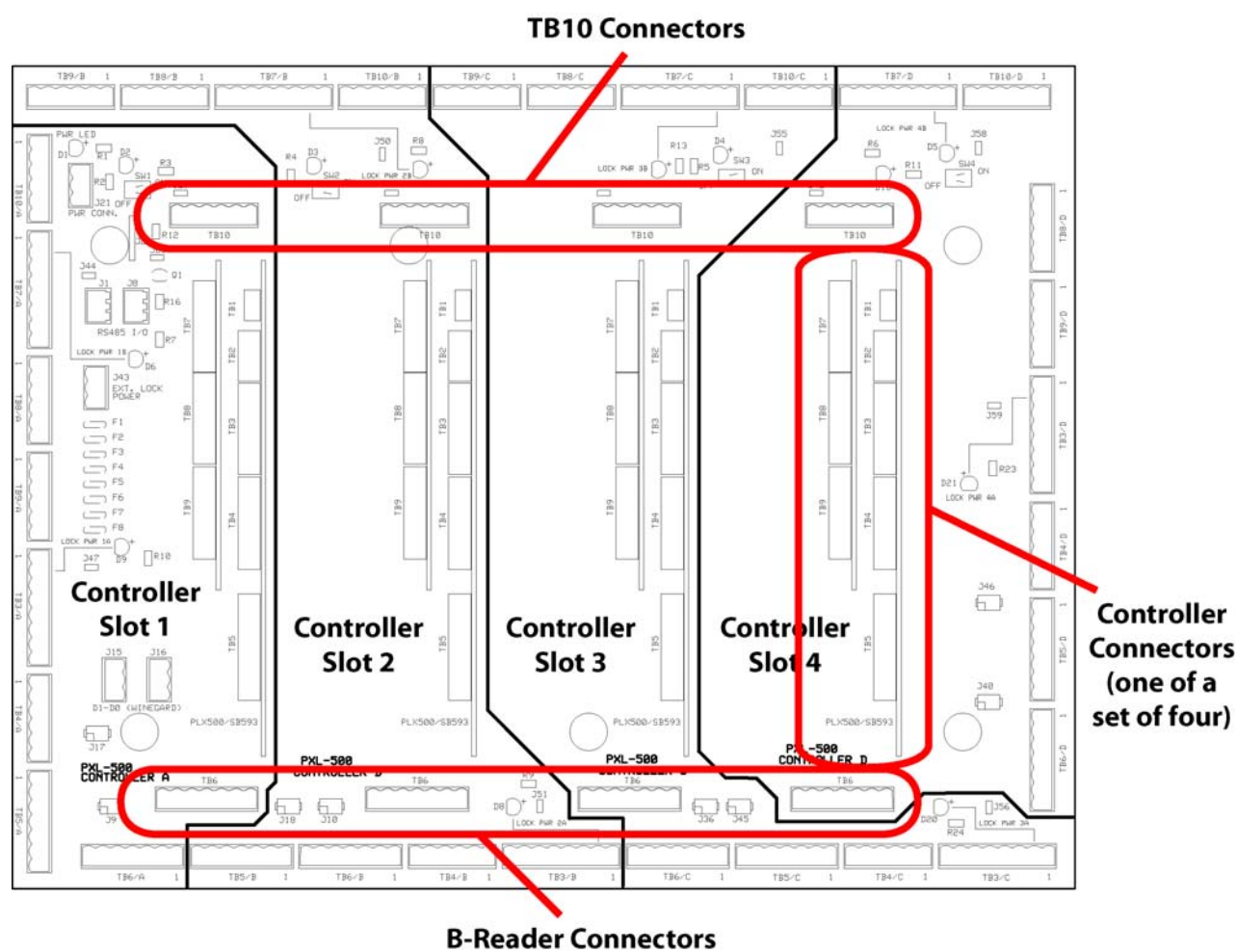

Figure 27: B-Reader and TB10 Backplane Connection Locations

# Eight-Door Concentrator

## 4.1 B-Reader Jumper Cables

Four sets are provided with the concentrator. These cables connect the individual controller B-Reader connections to the concentrator. This wiring diagram is provided should a reader jumper cable be lost.

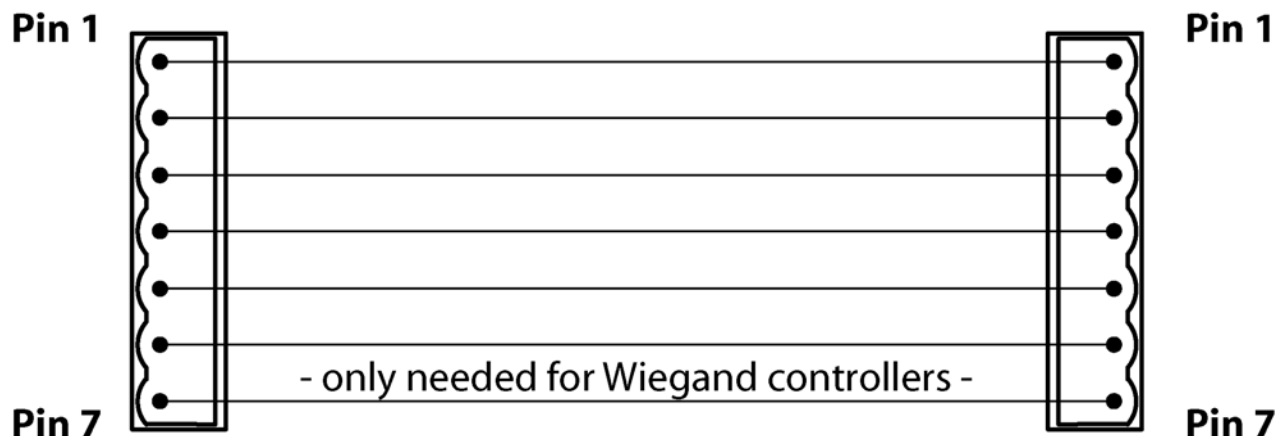

Figure 28: B-Reader Jumper Cable Wiring

## 4.2 TB10 Relay Output Jumper Cables

Four sets are provided with the concentrator. These cables connect the individual controller TB10 connections to the concentrator. This wiring diagram is provided should a TB10 jumper cable be lost.



Figure 29: TB10 Jumper Cable Wiring

# Eight-Door Concentrator

## 5.0 Cabinet Operation

### 5.1 Powering ON the Controllers

Near the top of each controller is a power switch and a power ON LED. This provides maximum flexibility in powering up the unit and in swapping boards. When ready, simply switch ON each controller, one-at-a-time, and verify power on by both the backplane power ON LED and the controller's own power LED.

Lock power ON is signified by a separate set of LEDs, one for each lock relay. These LEDs will be ON when lock power is being supplied to the lock relay through the lock jumpers.

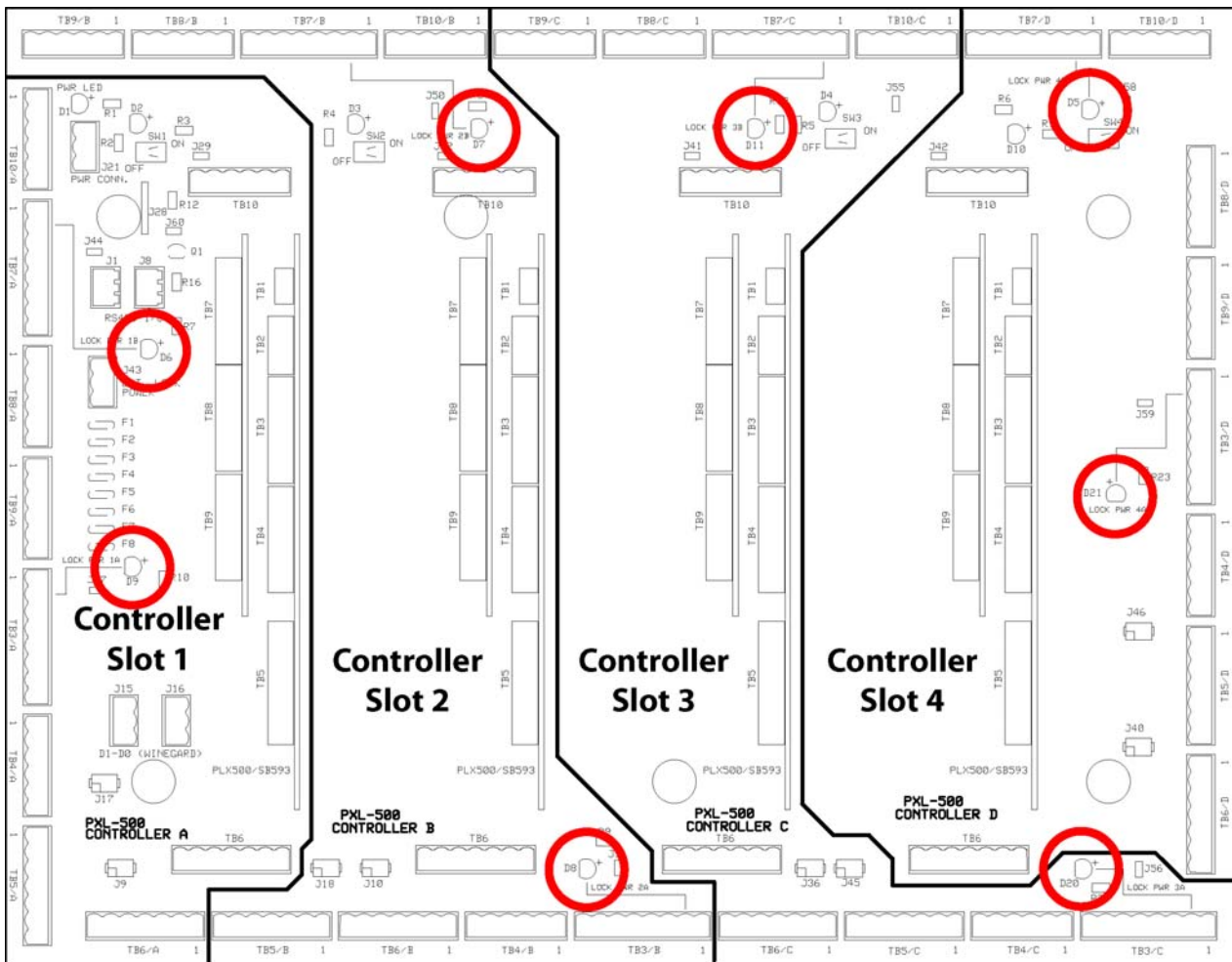

Figure 30: Lock Power LED Locations

# Eight-Door Concentrator

---

## 5.2 Closing the Cabinet

The Concentrator cabinet cover has a slip-hinge that allows you to completely remove the cover when working inside the unit. It has a single lock that provides cabinet security.

## 5.3 Front Cover LEDs

There are two LEDs in the upper-left corner of the unit, visible through the cabinet cover.

- The left LED is for controller power ON.
- The right LED is for network communication activity.